

Snakky Max

UK English



DOC. NO. **H 239U 00**
EDITION 1 2004-07

NECTA
VENDING SOLUTIONS SpA
A company of
N&W GLOBAL VENDING GROUP

Sede legale: Via Roma 24
24030 Valbrembo (BG) Italia
Web: www.nwglobalvending.com

Telefono +39 035 606111
Fax +39 035 606460
Trib. Bergamo Reg. Imp. n. 2534
R.E.A. Bergamo n. 319295

DICHIARAZIONE DI CONFORMITA'
DECLARATION OF CONFORMITY
DÉCLARATION DE CONFORMITÉ
KONFORMITÄTSEKTLÄRUNG
DECLARACIÓN DE CONFORMIDAD
DECLARAÇÃO DE CONFORMIDADE
VERKLARING VAN OVEREENSTEMMING
INTYG OM ÖVERENSSTÄMMELSE
OVERENSSTEMMELSESERKLÆRING
YHDENMUKAISUUSTODISTUS

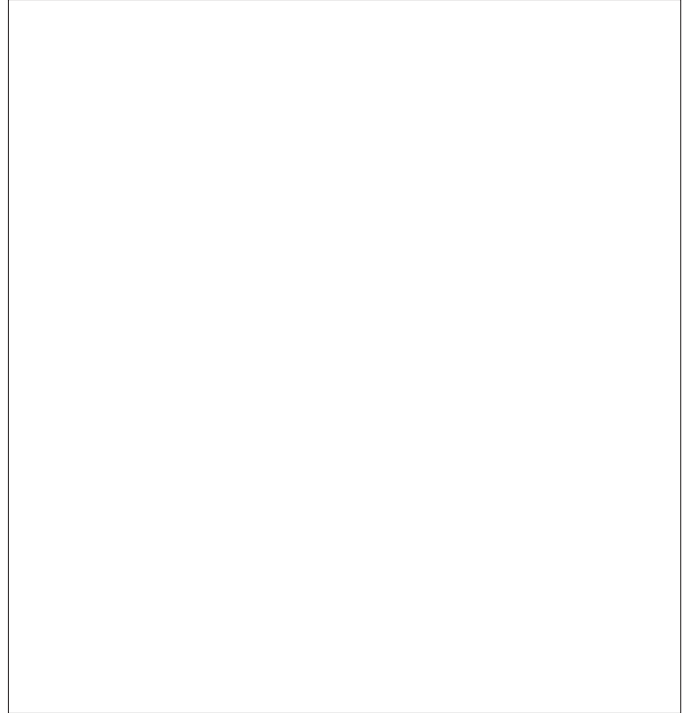

Valbrembo, 03/05/2001

Dichiara che la macchina descritta nella targhetta di identificazione, è conforme alle disposizioni legislative delle direttive: **89/392, 89/336, 73/23 CEE** e successive modifiche ed integrazioni.

Declares that the machine described in the identification plate conforms to the legislative directions of the directives: **89/392, 89/336, 73/23 EEC** and further amendments and integrations.

Déclare que l'appareil décrit dans la plaque signalétique satisfait aux prescriptions des directives: **89/392, 89/336, 73/23 CEE** et modifications/intégrations suivantes.

Erklärt, daß das im Typenschild beschriebene Gerät den **EWG** Richtlinien **89/392, 89/336, 73/23** sowie den folgenden Änderungen/Ergänzungen entspricht.

Declara que la máquina descrita en la placa de identificación, resulta conforme a las disposiciones legislativas de las directivas: **89/392, 89/336, 73/23 CEE** y modificaciones y integraciones sucesivas.

Declara que o distribuidor descrita na chapa de identificação é conforme às disposições legislativas das directivas **CEE 89/392, 89/336 e 73/23** e sucessivas modificações e integrações.

Verklaart dat de op de identificatieplaat beschreven machine overeenstemt met de bepalingen van de **EEG** richtlijnen **89/392, 89/336** en **73/23** en de daaropvolgende wijzigingen en aanvullingen.

Intyggar att maskinen som beskrivs på identifieringsskylten överensstämmer med lagstiftningsföreskrifterna i direktiven: **89/392, 89/336, 73/23 CEE** och påföljande och kompletteringar.

Det erklæres herved, at automaten angivet på typeskiltet er i overensstemmelse med direktiverne **89/392, 89/336** og **73/23 EU** og de senere ændringer og tillæg.

Forsikrer under eget ansvar at apparatet som beskrives i identifikasjonsplaten, er i overensstemmelse med vilkårene i EU-direktivene **89/392, 89/336, 73/23** med endringer.

Vahvistaa, että arvokyltissä kuvattu laite vastaa **EU**-direktiivien **89/392, 89/336, 73/23** sekä niihin myöhemmin tehtyjen muutosten määräyksiä.

ANTONIO CAVO

C.E.O



THE INTERNATIONAL CERTIFICATION NETWORK

CERTIFICATE

**IQNet and its partner
CISQ/IMQ-CSQ**

hereby certify that the organization

NECTA VENDING SOLUTIONS SPA

VIA ROMA 24 - 24030 VALBREMBO (BG) Italy

VIA DEL CHIOSO ANG. CAPITANI DI MOZZO - 24030 MOZZO (BG) Italy

for the following field of activities

Design, manufacturing and sale of electrical/electromechanical vending machines

*Refer to quality manual for details of applications to ISO 9001:2000 requirements
has implemented and maintains a*

Quality Management System

which fulfills the requirements of the following standard

ISO 9001:2000

Issued on: 2002 - 09 - 04

Registration Number: **IT - 12979**



Fabio Roversi
President of IQNet



Gianrenzo Prati
President of CISQ

IQNet partners*:

AENOR, Spain AFAQ, France AIB-Vinçotte International Belgium APCER, Portugal CISQ, Italy CQC, China CQM, China CQS, Czech Republic DQS, Germany DS, Denmark ELOT, Greece FCAB, Brazil FONDONORMA, Venezuela HKQAA, Hong Kong ICONTEC, Colombia IRAM, Argentina IQA, Japan KEMA, Netherlands KFQ, Korea MSZT, Hungary NCS, Norway NSAI, Ireland OQS, Austria PCBC, Poland PSB, Singapore QMI, Canada SFS, Finland SII, Israel SIO, Slovenia SOS, Switzerland IQNet is represented in the USA by the following partners: AFAQ, AIB-Vinçotte International, CISQ, DQS, KEMA and NSAI

*The list of IQNet partners is valid at the time of issue of this certificate. Updated information is available under www.iqnet-certification.com

Federazione - Federation



a member of IQNet

CISQ è una Federazione consorziale ed indipendente di enti di certificazione dei Sistemi di Gestione aziendali, operanti ciascuno nel settore di propria competenza.

CISQ is a multi-sector, independent, non-profit Federation of Italian organizations for the certification of company Management Systems, each operating in its own sector of responsibility.

CERTIFICAZIONE DEI SISTEMI DI GESTIONE AMBIENTALE DELLE AZIENDE
CERTIFICATION OF COMPANIES ENVIRONMENTAL MANAGEMENT SYSTEMS



CERTIFICATO n. **9191.ZAV2**
CERTIFICATE n.

SI CERTIFICA CHE IL SISTEMA DI GESTIONE AMBIENTALE DI
WE HEREBY CERTIFY THAT THE ENVIRONMENTAL MANAGEMENT SYSTEM OPERATED BY

NECTA VENDING SOLUTIONS S.p.A.

SITO
SITE

Via Roma, 24 - 24030 VALBREMBO (BG)

UNI EN ISO 14001

È CONFORME ALLA NORMA
IS IN COMPLIANCE WITH THE STANDARD

PER LE SEGUENTI ATTIVITÀ
CONCERNING THE FOLLOWING ACTIVITIES

Apparecchiature elettromeccaniche/elettroniche per la
distribuzione automatica e la ristorazione
Electronic/electromechanical vending-machines

IL PRESENTE CERTIFICATO È SOGGETTO AL RISPETTO DEL REGOLAMENTO
PER LA CERTIFICAZIONE DEI SISTEMI QUALITÀ EDI GESTIONE DELLE AZIENDE
THE USE AND THE VALIDITY OF THE CERTIFICATE SHALL SATISFY THE REQUIREMENTS
OF THE RULES FOR THE CERTIFICATION OF COMPANY QUALITY AND MANAGEMENT SYSTEMS

Prima emissione
First issue

19 Dicembre 1997

Emissione corrente
Current issue

31 Marzo 2000

Data di scadenza
Expiring date

E.A. 19



Mod. 417 - REV. 04/99

IMO - VIA QUINTILIANO, 43 - 20138 MILANO
Gestione Ambientale con periodicità triennale secondo le procedure dell'IMQ S.p.A.
The validity of the certificate is submitted to annual audit and a reassessment of the entire Environmental Management System within three years according to IMQ S.p.A. rules

TABLE OF CONTENTS

INTRODUCTION	PAGE 2	FILLER MENU	PAGE 12
IDENTIFICATION OF THE VENDING MACHINE	PAGE 2	STATISTICS	PAGE 13
IN THE EVENT OF FAILURES	PAGE 2	PRICES BY SINGLE SELECTIONS	PAGE 13
TRANSPORT AND STORAGE	PAGE 2	CHANGE TUBES CONTROL	PAGE 13
USING THE VENDING MACHINE	PAGE 3	SPECIAL SELECTIONS	PAGE 13
POSITIONING THE VENDING MACHINE	PAGE 3	TEST	PAGE 14
WARNING FOR INSTALLATION	PAGE 3	GSM PRE-ALARMS	PAGE 14
PRECAUTIONS IN USING THE MACHINE	PAGE 3	EVADTS TRANSFER	PAGE 14
WARNING FOR SCRAPPING	PAGE 3	TECHNICIAN MENU	PAGE 15
TECHNICAL SPECIFICATIONS	PAGE 4	PRESENT FAILURES	PAGE 16
ACCESSORIES	PAGE 4	PROGRAMMING THE PARAMETERS	PAGE 17
POWER CONSUMPTION	PAGE 4	STATISTICS	PAGE 22
CHANGEABLE COMBINATION LOCK	PAGE 5	TEST	PAGE 23
		MACHINE INFORMATION	PAGE 24
		GSM	PAGE 24
LOADING AND CLEANING	PAGE 6	MAINTENANCE	PAGE 25
MAIN SWITCH	PAGE 6	PRINTED BOARD FUNCTIONS AND INDICATOR LAMPS	PAGE 25
CONFIGURING THE SPIRALS	PAGE 6	CONFIGURING THE BOARD	PAGE 25
HYGIENE AND CLEANING	PAGE 7	SOFTWARE UPDATE	PAGE 25
LOADING PRODUCTS	PAGE 7	CONFIGURING THE TRAYS	PAGE 26
START-UP	PAGE 8	PRODUCT SPACERS	PAGE 26
NOISE LEVEL	PAGE 8	PRODUCT EJECTOR	PAGE 26
		REPLACING THE SPIRALS	PAGE 26
INSTALLATION	PAGE 9	REMOVING THE TRAYS	PAGE 26
UNPACKING THE VENDING MACHINE	PAGE 9	CHANGING THE NUMBER OF TRAYS	PAGE 27
INSTALLING THE PAYMENT SYSTEM	PAGE 9	CHANGING THE TRAY CONFIGURATION	PAGE 27
CONNECTION TO THE POWER SUPPLY	PAGE 10	POWER SUPPLY UNIT	PAGE 28
CONTROLS AND INFORMATION	PAGE 10	ACCESS TO THE COOLING UNIT	PAGE 28
INTERNAL COMPONENTS	PAGE 11	PROGRAMMING MENU - SUMMARY	PAGE 31
MAIN SWITCH	PAGE 11	WIRING DIAGRAM	PAGE 58
DISPENSING COMPARTMENT			
MANUAL RELEASE	PAGE 11		
OPERATING MODES	PAGE 12		
USER INTERFACE	PAGE 12		
DIRECT SELECTIONS	PAGE 12		
NORMAL OPERATING MODE	PAGE 12		

INTRODUCTION

This technical documentation is part and parcel of the vending machine and must always follow the machine in case it is moved or transfer of ownership, so as to allow consultation by different operators.

Before starting installation and using the machine, it is first necessary to carefully read and understand the instructions contained in this manual, as they offer important information on installation safety, operating instructions and maintenance.

This manual is divided into three chapters.

The **first chapter** describes the loading and routine maintenance operations which are carried out in areas of the machine accessible with simple use of the door key, without using any other tools.

The **second chapter** contains the instructions for correct installation and all information necessary for optimum use of the machine.

The **third chapter** describes maintenance operations which involve the use of tools to access potentially dangerous areas.

The operations described in the second and third chapters must be carried out only by personnel who have the specific knowledge of the machine functioning from a point of view of electrical safety and health regulations.

IDENTIFICATION OF THE VENDING MACHINE AND ITS CHARACTERISTICS

Each machine is identified by its own serial number, indicated on the rating plate attached inside the cabinet on the right side.

This plate (see figure below) is the only one acknowledged by the manufacturer as the identification of the apparatus, and carries all the data which readily and safely give technical information supplied by the manufacturer. It also assists in the spare parts management.

IN THE EVENT OF FAILURES

In most cases, any technical problems are corrected by small repair operations; however, before contacting the manufacturer we recommend that this manual be read carefully.

Should there be serious failures or malfunctions, contact the following:

NECTA VENDING SOLUTIONS SpA
Via Roma 24
24030 Valbrembo
Italy - Tel. +39 - 035606111

TRANSPORT AND STORAGE

To prevent any damage, special care should be taken when loading or unloading the vending machine.

The machine can be lifted by a motor-driven or manual forklift truck, and the forks are to be placed underneath the machine from the side clearly indicated by the symbol on the cardboard package.

Do not:

- overturn the vending machine;
- drag the vending machine with ropes or similar;
- lift the vending machine by its sides;
- lift the vending machine with slings or ropes;
- shake the vending machine.

The machine should be stored in a dry room where the temperature remains between 0°C and 40°C.

Avoid stacking machines one on top of the other and always keep it upright as indicated by the arrows on the packing.

Fig. 1

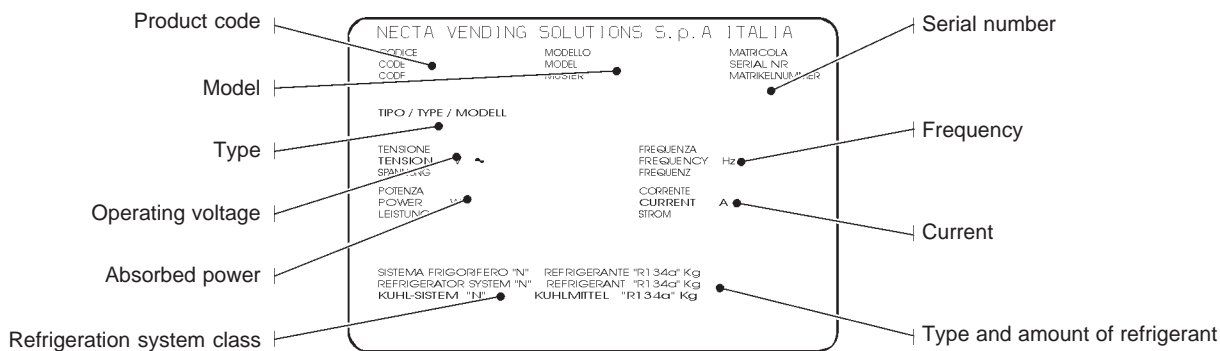

USING THE VENDING MACHINE FOR PACKAGED PRODUCTS

A different sale price can be set for each product selection by the machine electronic control. The various functions are programmed through the selection keypad without any need for additional equipment.

All models are equipped with variable configuration trays, adding or removing dividers, spirals and ratiomotors; therefore the machine can be easily suited to specific needs.

All trays are preset for the operation of up to 6 selections (maximum setting).

The product compartments are equipped with independent motors and spirals; each selection will continue its operation autonomously even if the other selections are disconnected.

POSITIONING THE VENDING MACHINE

The vending machine is not suitable for outdoor installation. It must be positioned in a dry room where the temperature remains between 5°C and 32°C, and not where water jets are used for cleaning (e.g. in large kitchens, etc.).

To ensure correct machine operation we recommend installing the air baffle plate / spacer (80 mm) to the back of the machine (see Fig. 2).

Warning!

Incorrect ventilation may compromise the proper functioning of the cooling unit.

The machine should be positioned with a maximum inclination of 2°.

If necessary provide proper levelling by way of the adjustable feet included.

WARNING FOR INSTALLATION

The machine installation and the following maintenance operations should be carried out by qualified personnel only, who are trained in the correct use of the machine according to the standards in force.

The machine is sold without payment system, therefore the installer of such a system is responsible for any damage to the machine or to things and persons caused by faulty installation.

The integrity of the machine and compliance with the standards of the relevant systems must be checked at least once a year by qualified personnel.

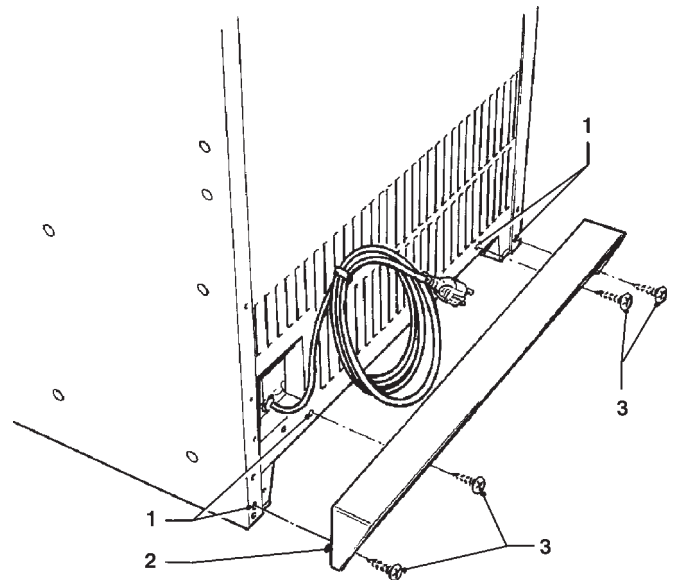

Fig. 2

- 1 - Securing holes
- 2 - Spacer
- 3 - Fastening screws

PRECAUTIONS IN USING THE MACHINE

The following precautions will assist in protecting the environment:

- use biodegradable products only to clean the machine;
- adequately dispose of all containers of the products used for loading and cleaning the machine;
- keep the machine away from heat sources;
- regularly check the condition of the door seal to limit any heat dispersion;
- limit as much as possible door opening time during loading operations to avoid temperature increase inside the cabinet and subsequent power consumption.

WARNING FOR SCRAPPING

Whenever the machine is to be scrapped, the laws in force regarding environment protection should be strictly observed. More specifically:

- ferrous and plastic materials and the like are to be disposed of in authorized areas only;
- insulating materials should be recovered by qualified companies;
- the gas inside the cooling unit, regardless of the type (see the identification plate), should be recovered by qualified companies by means of special equipment.

TECHNICAL SPECIFICATIONS

Power supply voltage	230	V~
Power supply frequency	50	Hz
Absorbed power	560	W
Max. operating conditions:		
Ambient temperature	32	°C
Relative humidity	65	%

Refrigeration system:

Compressor's refrigeration output	620	W
Fan-forced evaporator		
Programmable defrosting cycle		

DIMENSIONS

Height	1830	mm
Width	740	mm
Depth	855	mm
Overall depth with door open	1350	mm
Weight	225	Kg

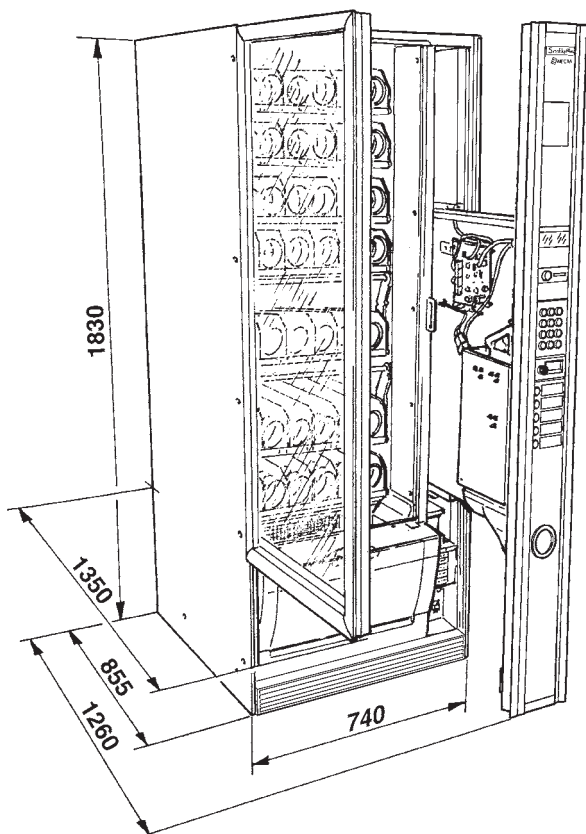

Fig. 3

PAYMENT SYSTEM

The machine is supplied with all electrical prearrangement for systems with Executive, BDV and MDB protocol, as well as for installation of 24 V DC validators.

Beside the coin mechanism housing, suitable space is provided for the installation (optional) of the most widely used payment systems.

SALES PRICES

A different programmable price can be set for each single selection.

COIN BOX

Cover and lock are available as an optional feature.

CONTROLS AND SAFETY DEVICES

- Payment system compartment switch
- Timeout for power supply to dispensing motors
- Compressor overheating protection
- Line fuses
- Fuses on transformer primary and secondary windings

ACCESSORIES

A wide range of accessories can be installed on the machine, to vary its performance.

The installation kits are supplied with their own installation and test instructions, which must be strictly observed to ensure the machine safety.

Installation and the following testing operations must be carried out exclusively by personnel who have a specific knowledge of the machine functions from a point of view of electrical safety and health regulations.

POWER CONSUMPTION

The machine power consumption depends on many factors, such as temperature and ventilation of the room where it is installed, temperature of loaded products, internal temperature of the refrigerated box.

Under average conditions, and namely:

- Ambient temperature: °C 20
- Refrigerated box temperature: °C 5
- temperature of loaded products (machine completely empty) °C 20

the following power consumption levels resulted:

- Hourly stand-by power consumption Wh 266

The above power consumption calculated from average data should only be taken as an indication.

CHANGEABLE COMBINATION LOCK

Some machine models are fitted with a changeable combination lock.

The lock is supplied with a silver colour key to be used for normal opening and closing.

The lock can be customised by means of a kit, available as accessory, permitting changing of the lock combination.

This kit includes a change key (black) for the current lock combination as well as the change (gold) and use (silver) keys for the new combination.

Sets of change and use keys with other combinations can be supplied on request.

Additional sets of use keys (silver) may be requested, indicating the combination stamped on the keys.

Generally, only the use key (silver) is used, while the combination change keys (gold) can be kept as spares.

Do not use the change key for normal opening, as it may damage the lock.

To change combination do as follows:

- open the machine door to avoid forcing the rotation;
- lightly lubricate the inside of the lock with a spray;
- insert the current change key (black) and rotate to the change position (reference notch at 120°);
- remove the current change key and insert the change key (gold) with the new combination;
- rotate to the close position (0°) and remove the change key.

The lock will now have the new combination.

The keys with the old combination cannot be used for the new combination.

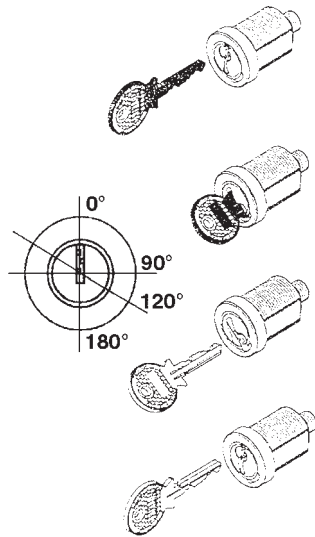

Fig. 4

Chapter 1 LOADING AND CLEANING

MAIN SWITCH

When extracting the sliding compartment, a special switch (see Fig. 5) disconnects the power from the machine electrical system to allow maintenance and cleaning operations in full safety.

The only parts that stay energised are those protected by covers and carrying a plate with the warning “disconnect the power before removing the cover”.

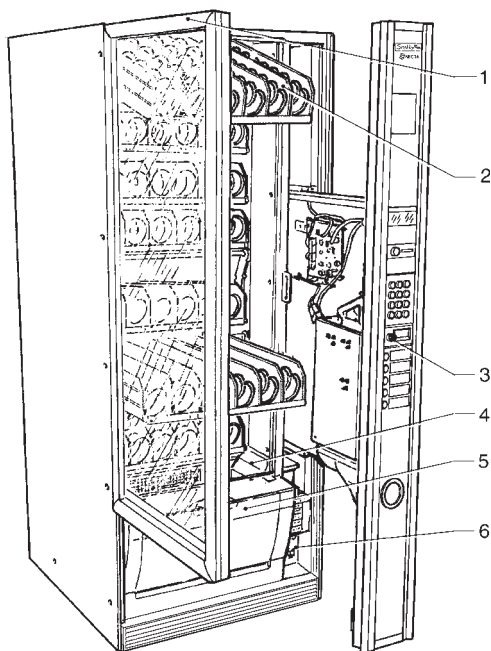

Fig. 5

- 1 - Door opening grip
- 2 - Trays
- 3 - Lock
- 4 - Product passage photocells (optional)
- 5 - Product dispensing compartment
- 6 - Main switch
- 7 - Sliding compartment

CONFIGURING THE SPIRALS

According to the size of the products to be dispensed, each machine can be fitted with a variable number of trays (maximum 7), removable partitions and with dispensing spirals of different pitch.

The spirals can be housed either in 152 mm compartments (two spirals, right-hand and left-hand, in each product holder) for large size products, or into 75 mm compartments (one right-hand spiral in each product holder) for small size products.

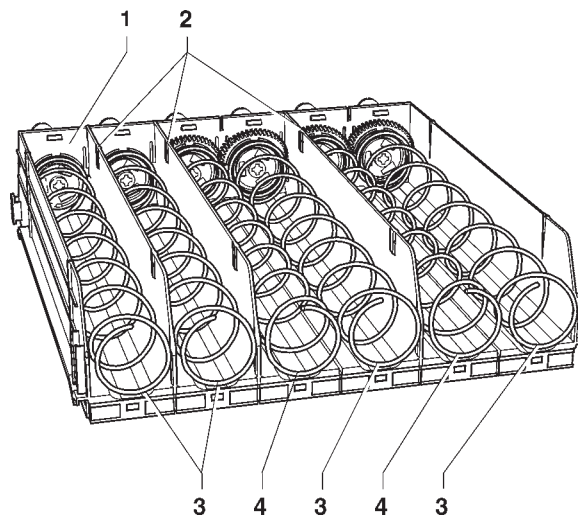

Fig. 6

- 1 - Tray
- 2 - Mobile walls
- 3 - Right-hand spiral
- 4 - Left-hand spiral

When dispensing sticks of candies or similar products, it is possible to set the rotation of the spirals to 180° instead of 360° for the 75 mm compartments and use a special right hand spiral fitted with a divider (see Fig. 7), doubling the capacity of the compartments.

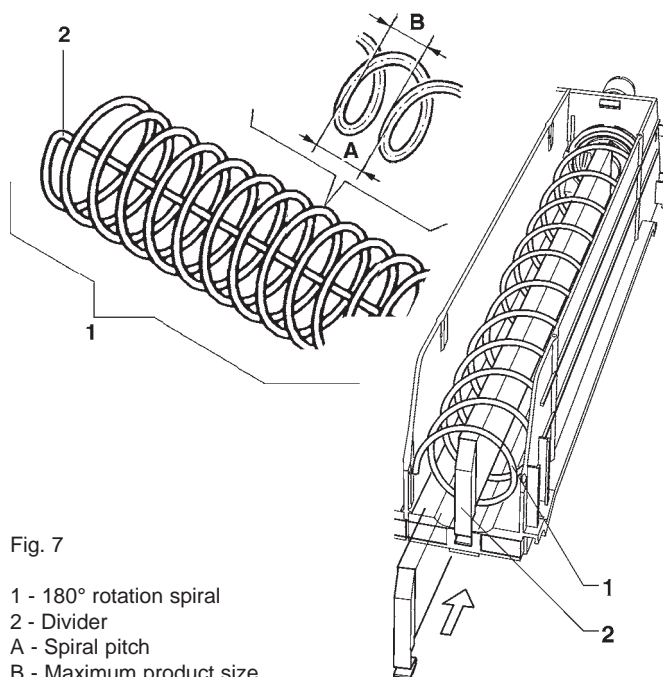

Fig. 7

- 1 - 180° rotation spiral
- 2 - Divider
- A - Spiral pitch
- B - Maximum product size

It is possible to insert a divider in the already installed spirals (see Fig. 7).

As standard feature or using special kits, the machine can be equipped with small compartments, suitable for dispensing cans, plastic bottles up to 69 mm dia., 0.2 litre Tetra-Paks.

The compartments equipped in this way can be recognised by the shape of the product support bracket (see Fig. 8).

Some bottle types can be dispensed without using the supports.

Most bottles can be dispensed without using any special accessories, loading the bottles up side down, so that the

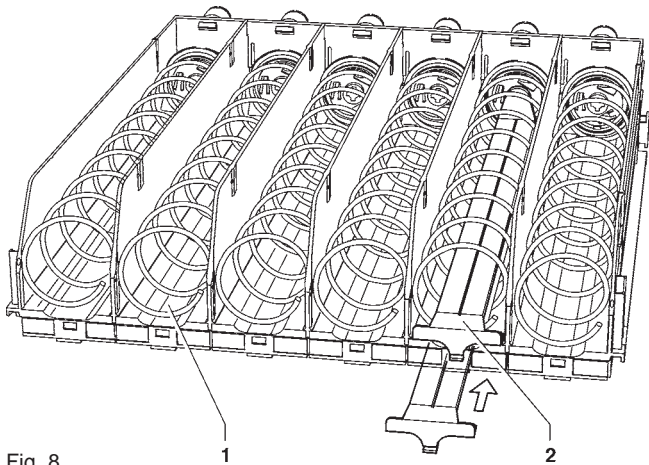

Fig. 8

- 1 - Tray groove
- 2 - Product support

cap slides in the compartment channel.

The spirals can be positioned with 22,5 degree steps by pulling them towards the front and rotating them in the direction of ejection.

Normally, the products can be dispensed without any problems when the spiral end is in the lower centre position.

The maximum size (see Fig. 6) and the number of products, the pitch and the direction of rotation of the spirals are shown in the following table.

	A mm.	B mm.	N°
↻↻	80	76	6
	64	60	7
	54	50	8
	46	42	10
	40	36	11
	34	30	13
	30	26	15
	24	20	19
↻	24 (180°)	20	19+19

The machine is supplied with a table indicating the optimum setting for the different product types. The configuration can be changed following the indications of the relevant chapter.

HYGIENE AND CLEANING

According to current health and safety regulations, the operator of vending machines is responsible for their hygiene and cleaning.

The vending machine is not suitable for outdoor installation. It must be positioned in a dry room where the temperature remains between 5°C and 32°C, and not where water jets are used for cleaning.

This vending machine should only be used to sell and dispense packaged products that do not need refrigeration to be preserved.

Strictly comply to the producer's specifications regarding storage method and expiry date for each product.

Any other use is unsuitable and thus potentially dangerous.

It is advisable to use sanitising products (chlorine based detergent or similar) to clean all surfaces even if not in direct contact with food.

Some parts of the machine can be damaged by strong detergents.

The manufacturer declines all responsibility for damage to persons caused by the non-compliance with current regulations.

At least every six months it is necessary to clean the ventilation grilles of the cooling system using a vacuum cleaner or compressed air, doing as follows:

- with the vending machine disconnected from the power supply, remove the front grille, completely undoing the two screws;
- remove the air intake grille.
- after cleaning the grilles, reassemble everything in the reverse order.

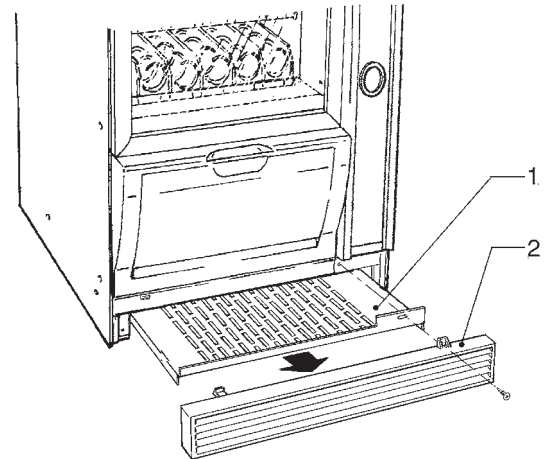

Fig. 9

- 1 - Air-intake grille
- 2 - Front grille

Under no circumstances should sprayed water be used.

Before any maintenance operation always switch the machine off.

The integrity of the machine and compliance with the standards of the relevant systems must be checked at least once a year by qualified personnel.

LOADING PRODUCTS

- Remove one tray at a time, lifting it and pulling it past the retaining slide. The upper trays will tilt downwards to facilitate loading.

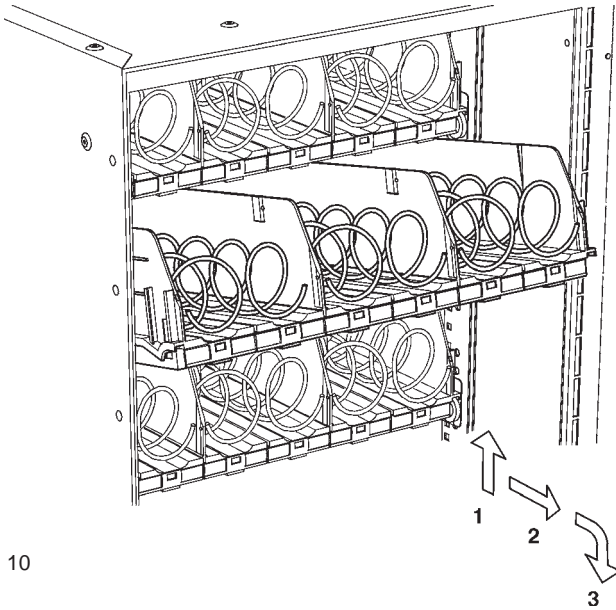

Fig. 10

- Load all products starting at the front, without inserting products with a temperature above 30°C, ensuring that all spaces are filled. The bottom of the product must rest at the bottom of the compartment with the label facing the window so that it can be identified.

All products should load easily, do not insert products which are too large for the space.

- Push in the trays completely, ensuring that they go past the retaining slide.

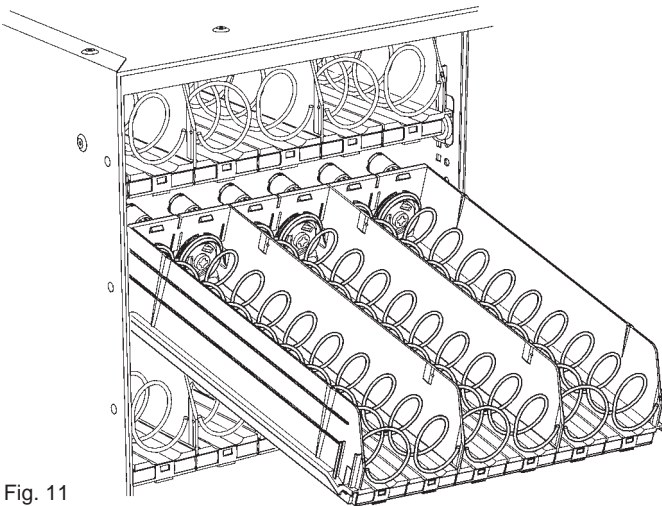

Fig. 11

The sealed end of bags may be caught under the spiral, preventing the free fall of the product. Fold the seal towards the front of the unit and upwards before inserting the product in the spiral.

More fragile products must be placed on the lower trays to prevent damage when they drop.

Very thin products can be dispensed only using the special spacer.

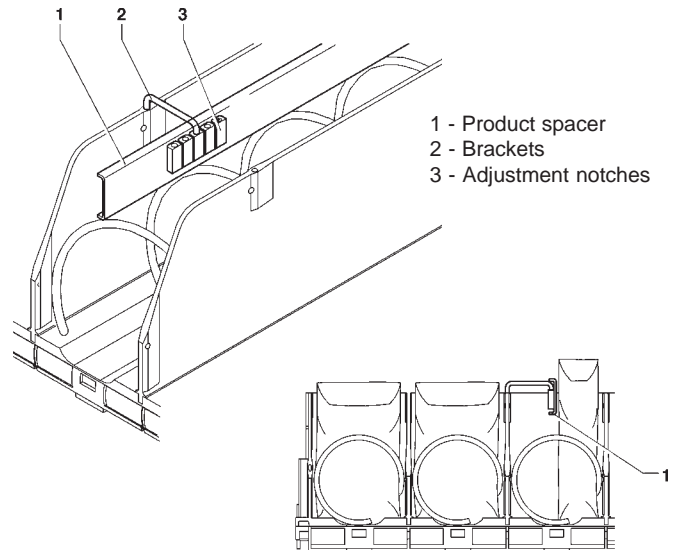

Fig. 12

START-UP

Each time the machine is started the number of trays connected to the system are checked by the electronic controls and indicated on the display.

Also the number of actually connected compartments is checked.

The display will indicate in a sequence information regarding:

- software version
- presence of dispensing detection photocells
- number of trays and compartments
- presence of dispensing compartment lock device
- internal sensor temperature.

NOISE LEVEL

The continuous, weighted equivalent acoustic pressure level is below 70 dB.

Chapter 2 INSTALLATION

The machine installation and the following maintenance operations should be carried out by qualified personnel only, who are trained in the correct use of the machine and are aware of the specific risks of such operations.

The machine is not suitable for outdoor installation, it must be installed in a dry room where the temperature remains between 5°C and 32°C.

It cannot be positioned where water jets are used for cleaning (e.g. in large kitchens, etc.).

The machine should be positioned with a maximum inclination of 2°.

The relative humidity must not exceed 65%.

UNPACKING THE VENDING MACHINE

After removing the packing, ensure that the machine is intact.

If the vending machine is found to be damaged, immediately inform the carrier and do not use the machine.

No packing elements (i.e. plastic bags, polystyrene foam, nails, etc.) should be left within the reach of children, as they are potentially dangerous.

Packing materials must be disposed of in authorised containers and the recyclable ones must be recovered by qualified companies.

If the vending machine had been laid down during transport, allow at least one hour before connecting it to the mains.

INSTALLING THE PAYMENT SYSTEM

The machine is sold without payment system, therefore the installer of such a system has sole responsibility for any damage to the machine or to things and persons caused by incorrect installation.

Install the coin mechanism paying attention, according to the type used, to:

- choose the most suitable securing holes;
- loosening the fastening screw and adjusting the coin slot chute according to the coin mechanism opening;
- loosen the fastening screws and adjust the selector opening lever;
- to aid installation the coin mechanism support plate can be lifted and rotated.

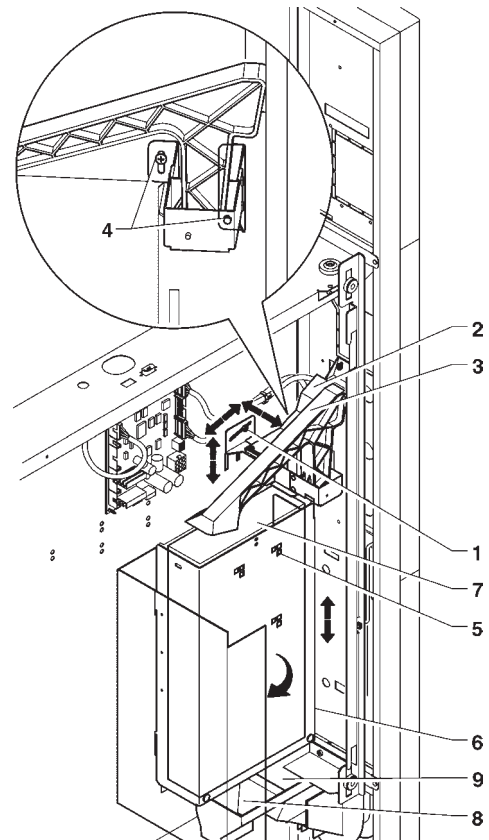

Fig. 13

- 1 - Coin chute fastening screw
- 2 - Coin chute
- 3 - Selector opening cam
- 4 - Selector lever fastening screw
- 5 - Coin mechanism securing holes
- 6 - Coin mechanism compartment door
- 7 - Coin mechanism
- 8 - Coin slot chute
- 9 - Coin return chute

CONNECTING THE MACHINE TO THE POWER SUPPLY

The machine is designed to operate under a single-phase 230 V~ voltage and is protected by T6.3 A fuses. Before making the connection, ensure that the rating corresponds to that of the power grid, and more specifically:

- the supply voltage rating must be within the range recommended for the connection points;
- the main switch should be capable of withstanding the peak load required, and at the same time ensure proper omni polar disconnection from the power grid with an opening gap of the contacts of at least 3 mm.

The switch, the power outlet and the plug must be located in an easily accessible position.

The electrical safety of the machine is ensured only when it is correctly earthed according to the safety standards in force.

This fundamental safety requirement must be duly verified, and if in doubt the system must be carefully tested by qualified technicians.

The power supply cable is of the type with a fixed plug. Any replacement of the power cable (see figure) should be made by qualified and suitably trained personnel only using cables type HO5 RN - F or HO5 V V-F or H07 RN-F with a 3x1-1.5 mm² section.

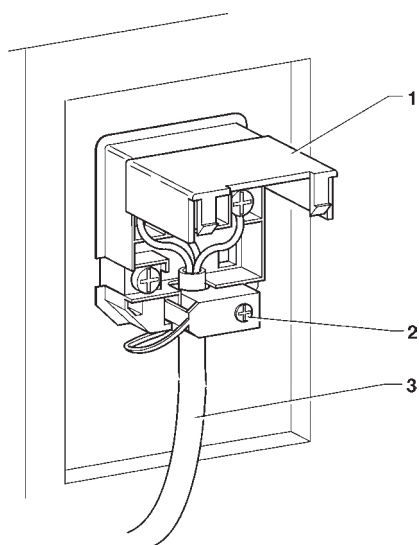

Fig. 14

- 1 - Lift cover
- 2 - Cable clamp
- 3 - Power supply cable

Do not use adapters, multiple sockets and/or extensions.

THE MANUFACTURER DECLINES ALL RESPONSIBILITY FOR ANY DAMAGE CAUSED BY NON-COMPLIANCE WITH THE ABOVE MENTIONED PRECAUTIONS.

CONTROLS AND INFORMATION

The user controls and information are located on the outside of the sliding compartment (see Fig. 14). The credit and all function messages are indicated on the display.

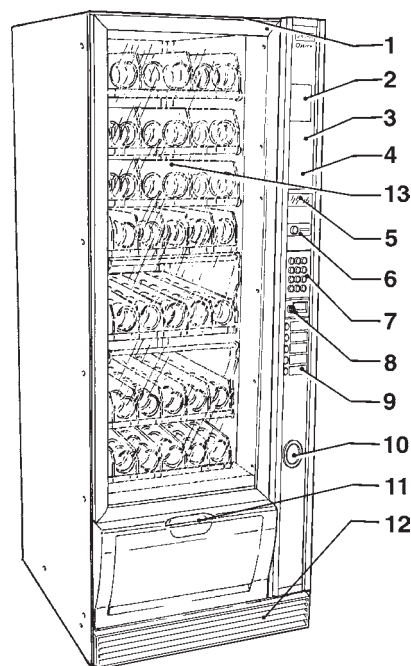

Fig. 1

- 1 - Door opening grip
- 2 - Advertising spaces
- 3 - Prearrangement for bill acceptor
- 4 - Prearrangement for key type payment systems
- 5 - Display
- 6 - Coin slot/return.
- 7 - Selection keypad
- 8 - Lock
- 9 - Direct selection buttons
- 10 - Coin return flap
- 11 - Product flap
- 12 - Removable ventilation grille
- 13 - Glass front

The keypad contains a series of numbered keys. To select a product, key in the number corresponding to the desired product.

Key © is used to cancel a selection already made.

Keys Ⓔ and Ⓕ are not available to the user; they are used only for programming.

INTERNAL COMPONENTS

The evaporator assembly mounted on the cabinet shelf comprises two fans, the evaporator, the air duct and a water retaining tray placed under the evaporator. The C.P.U. board (central processing unit) fitted inside the payment system compartment controls the different functions of the vending machine.

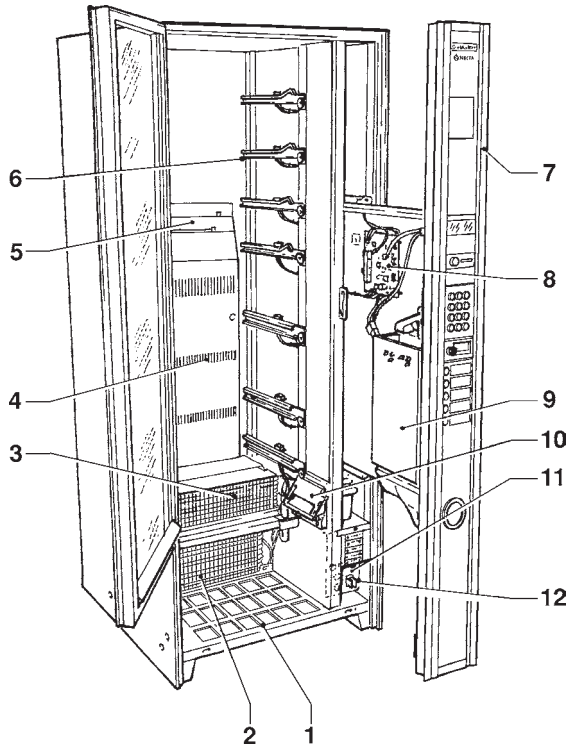

Fig. 15

- 1 - Product dispensing compartment housing
- 2 - Cooling unit condenser
- 3 - Cooling unit evaporator
- 4 - Cold air flow grilles
- 5 - Removable grille cover
- 6 - Tray guides
- 7 - Removable payment system compartment
- 8 - C.P.U. board
- 9 - Coin mechanism support
- 10 - Product passage photocells
- 11 - Power supply unit
- 12 - Payment system compartment door switch

The cooling unit is located in the lower part of the cabinet. When removing all covers of the ventilation grille, a uniform temperature is achieved in the cabinet, between 5°C and 20°C.

With the ventilation grille covers fitted, the temperature in the cabinet is diversified between the upper trays (12-15°C) and the lower trays with the holes on the duct open (5-7°C).

The cooling unit is defrosted automatically every 6 hours. In any case, the timing is programmable.

The power supply unit, mounted in the lower section of the cabinet, contains the relay card which activates the compressor, the protection fuses and the switch on the payment system door.

MAIN SWITCH

The power supply unit (see Fig. 28) is fitted with a micro-switch that, when opening the sliding compartment, disconnects the power from the machine electrical system, **except from the terminal board supporting the line cable, the line fuses and from the same switch area.**

Before removing the cover from these parts (indicated with a specific plate) it is necessary to disconnect the external switch.

The power supply can be reconnected, if necessary, by inserting the special key supplied with the machine.

All operations which require the machine to be energised with the door open must be carried out by qualified personnel who are aware of the specific risks of such condition.

DISPENSING COMPARTMENT MANUAL RELEASE

Some models are fitted with a lock device in the dispensing compartment that is released through electric control when a selection is made (see compartment lock parameters).

Should for any reason be necessary to open the compartment without electric power, do as follows:

- remove the last tray;
- remove the anti-theft grille;
- manually operate the lock device.

OPERATING MODES

The machine control software has three different function levels, which are:

- normal operation;
- filler menu;
- technician menu.

According to the operating mode, the display and keypad functions change as described in the following paragraphs.

USER INTERFACE

The interaction between system and operator happens through the following components:

- Liquid crystal display (LCD) 4 lines of 20 characters.
- External keypad configured via software with numeric keys from 0 to 9, having with the following functions in the in the filler and technician menus:

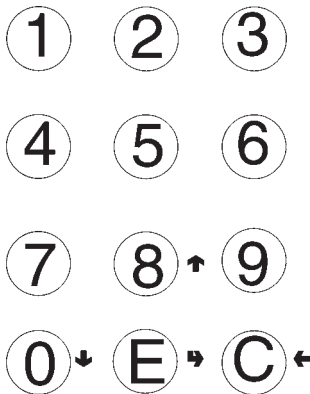

Fig. 16

Numeric keys

1 to 7 are used to select directly a menu item by keying in the corresponding number shown in the summary tables included in the appendix to this manual.

Next menu key Ⓞ:

"Ⓞ" is used to move to the next menu option. In the case of command management it varies the status of Logical Data where required, or in the case of Numeric Data it writes the value 0.

Previous menu key Ⓢ:

"Ⓢ" is used to move to the next menu option. In the case of command management it varies the status of Logical Data where required, or in the case of Numeric Data it writes the value 8.

Enter key ⓔ:

"ⓔ" is used to move from a menu to a sub-menu or to enter a command.

Exit key ⓐ:

"ⓐ" is used to move from a sub-menu to the higher level menu, or to exit from the current command.

DIRECT SELECTIONS

The vending machine can be fitted (as standard feature or as optional according to the model) with a 5-button keypad to which allocate a group of selection.

After enabling the direct selection function, it will be possible to allocate a group of selections to each key by specifying the start and end numbers of the series.

The selections, as long as in a sequence, can be also from different trays. The products are dispensed alternating from each of the spirals that are grouped in a direct selection.

All selections belonging to the same group must have the same price.

For correct safety management of the selections it is advisable that also a dispensing detection device be installed in the machine.

NORMAL OPERATING MODE

The machine is preset to "Normal operation" mode when connected to the power supply and the payment system door is closed (see door switch - Fig. 24).

The lighting is switched on and the messages for the customer are indicated on the display.

FILLER MENU

The machine is preset to "Filler menu" when pressing the menu access button (located on the CPU board - see Fig. 17).

The keys "Ⓢ" and "Ⓞ" scroll through the menu items, which include:

"Statistics"	Data reading and display
"Single Prices" selection	Changing the price for one selection
"Tubes control"	Manual refill and release of change tubes
"Special selections"	Virtual selections Return of virtual price Two-motor selections Photocell parameters
"Test"	Test selection Motor test Autotest
"GSM"	Resetting pre-alarm counters
"EVADTS"	Connection

If a menu is not enabled during programming, a title is displayed in the list but it cannot be accessed.

Price button Ⓣ

Key Ⓣ is used to access directly the price/selection combination of time band 0, if the function is enabled in the "Programming" menu.

STATISTICS

Data on the machine operations is stored in both general counters and relative counters, which can be reset without losing total data.

PRINT

Connect an RS232 serial printer having a Baud rate of 9600, 8 data bit, no parity, 1 stop bit to the serial port located on the push button board to print all of the statistics, and namely:

Total

- 1 - counter by single selection;
- 2 - counter by time bands;
- 3 - failure counter;
- 4 - coin mechanism data;
- 5 - photocell errors;
- 6 - motor errors;
- 7 - dispensing compartment lock errors

Relative

- 1 - counter by single selection;
- 2 - counter by time bands;
- 3 - failure counter;
- 4 - coin mechanism data;
- 5 - photocell errors;
- 6 - motor errors;
- 7 - dispensing compartment lock errors

The hardcopy printout will also contain the machine information, and namely:

- date/time of print
- machine name
- software version
- operator code
- machine code
- Installation date.

To connect the printer, do as follows:

- press the confirm print button “

DISPLAY

When pressing the confirm button “

RESETTING THE RELATIVE STATISTICS

Statistics can be reset for relative counters globally (all types of data) or selectively for:

- selections
- failures
- coin mechanism data
- photocell errors
- motor errors
- dispensing compartment lock errors

Press the confirm button “

Press the confirm button “

PRICES FOR SINGLE SELECTIONS

This function is used to change the sales price for each selection according to the time band.

Key 

CHANGE TUBES CONTROL

By accessing the “Tube control” function the change tubes can be filled or released manually.

Confirm refilling, and the display will indicate “Credit: —” which is the value of money available in change the tubes; insert the desired coin into the selector and the display will indicate the value of money available in the change tubes.

When confirming releasing, it will be possible to decide which tube to release. Each time the confirm button “

SPECIAL SELECTIONS

VIRTUAL SELECTIONS

This function is used to define a pair of selections that can be sold at a price different from the sum of the two selections, using a single selection number. 5 virtual selections can be programmed (80 to 84).

RETURN OF VIRTUAL PRICE

This function is used to define, in the event of failed second dispensing in a virtual selection, not to cash the price of the second selection (only if an MDB payment system or validator are used). With other payment systems, it can be decided whether or not return the entire amount.

SELECTIONS WITH TWO MOTORS

In order to dispense long products, dividers can be fitted so that two motors are used for each single selection.

With this function the operation of two motors can be combined, specifying the selection number of the second motor.

The first motor number will be the selection number, while the selection number of the associated motor will remain disabled.

Important notice!

After a failure to the motors of these selections, the machine configuration procedure in the “Spiral/Selection” menu must be followed.

DISPENSING DETECTION

The vending machine can be fitted (as standard feature or as optional according to the model) with a device that, by means of photocells, detects the passage of dispensed products.

This device permits, in the event of failed detection of the dispensed product:

- set a rotation time for the spiral beyond the limit switch, to overcome any jamming;
- return or not the paid amount;
- block further selections for the involved spiral.

TEST

SELECTIONS

This function is used to simulate the normal dispensing of products without inserting any money to check the functioning of the spiral rotation by pressing the selection buttons.

MOTOR TEST

It activates all motors in a sequence, indicating on the display the number of the involved selection.

AUTOTEST

A function to check, in a semiautomatic manner, the correct operation of some devices is implemented in the software.

Some checks occur automatically, others need the manual operation of the monitored component; button "➡" is pressed to go to the next check.

The monitored devices are:

"Keypad"

Press the button requested on the display; if it works correctly the request for the next button is presented.

"Temperature"

The value of temperature detected by the probe is displayed.

In the event of disconnection the value -11.0 is displayed.

In the event of a short-circuit the value 41.0 is displayed.

"←" to advance.

"Buzzer"

A series of sounds is emitted.

"Compressor"

The compressor is activated/deactivated using the "➡" and "←" buttons.

"Selections"

All selections are activated in a sequence.

"Coin mechanisms"

Checking that communication with the coin mechanism takes place correctly and which validator lines are set as being active.

"Photocells"

If the product detection device is present, the light beam reading and interruption are checked.

"Disp compt lock"

If the device for locking the dispensing compartment opening, use the "➡" and "←" buttons to lock and unlock the compartment opening.

"Direct keypad"

If fitted on the machine, the 5 buttons are checked sequentially.

Press the button requested on the display; if it works correctly the request for the next button is presented.

GSM PRE-ALARMS

The control software can send, via GSM modem, a signal indicating an "ending product" signal, when there is only a certain (programmable) number of pieces or grams of powder of a given product left. With this function the counters that control the pre-alarms are reset.

EVADTS TRANSFER

When activating this function, the machine awaits the connection with a device to acquire the EVADTS statistics.

TECHNICIAN MENU

Using the programming procedures described in this section, it is possible to set all variables regarding machine configuration.

The machine is preset to "Technician menu" when pressing button  from the filler menu.

N.B. By pressing again the button from the technician menu, the machine will return to "Filler" mode.

The keys "↑" and "↓" scroll through the technician menu items, which include:

Failures	Read Failures Reset failures Motor errors Motors status Reset motor errors	Statistics	Display	switched off Partial Total
			Delete	Partial Total
			Display relative	Partial Total
			Delete relative	Partial Total
			Display at start-up	
			Print relative	Partial Total
Program param. Cash	Prices Coin mechanisms		Delete	Partial Total
	Decimal point Master/Slave Bonus	Test	Test selections Motor test Autotest	
Spirals/select.	Spirals Photocells Disp comp lock Cold parameters	Miscellaneous	Machine info	Installation date Machine code Operator code
			Initialising	
Display	Language User messages Promotional message Personalised strings Display counters Contrast control		EVADTS	Pass code Security code Connection
		GSM	Pin code	
Cold paramet.	Temperature Enable cold unit Enable Food control Temperature log		Pre-alarms	Thresholds Counters Threshold association
			Number in bank	
Miscellaneous	Password Energy saving Menu masking Fluorescent lamps			

PRESENT FAILURES

READING

When the “Failure” function is displayed, press the confirm button “**↵**” to display the present failures.

If no failures are currently present, after pressing the confirm button “**↵**” the message “End failures” will be displayed.

The monitored failures are:

Compressor

The machine is locked if the compressor runs non-stop for more than 24 hours.

Coin mechanism

The machine is locked if it receives a pulse longer than 2 seconds on a validator line or the communication with the serial coin mechanism does not take place for more than 30 seconds (Executive protocol) or 75 seconds (BDV protocol).

RAM Data

One or more areas of the RAM contain wrong data which was corrected with the default values.

The machine will continue to function, but it would be advisable to initialise as soon as possible.

Probe

The machine is locked after 5 minutes if the internal temperature sensor is disconnected; the display will indicate a temperature of -11° C.

The machine is locked after one hour if a sensor short circuit is detected; in this case the display will indicate a temperature of +41° C.

Motor errors

With this function the failed motors are displayed for approximately 1 second.

Scrolling through all failed motors is automatic.

Note:

By restarting the machine any blocked motors are detected as not present.

Dispensing compartment lock

When the function “unlock compartment with dispensing” and the parameter “out of service if open” are active, the machine will lock if the locking device of the dispensing compartment remains blocked when closed or it does not close within the programmed time.

Motors status

This function is used to read the last failure that occurred in each spiral, even if the machine configuration has an empty position.

A motor can be in one of the following conditions:

- motor functioning;
- motor not present; when the motor is not detected at machine start-up.
- motor disconnected; when a motor detected at machine start-up is not detected during a selection.
- motor blocked; when the positioning button is not operated within the “timeout”.
- empty spiral; when, with the dispensing control installed, no dispensed product is detected.

Note:

By restarting the machine any motors with errors are detected as not present.

RESET

By confirming this function all current failures will be reset.

PROGRAMMING PARAMETERS

CASH

This set of functions controls all parameters regarding the payment systems and the sales prices.

SELECTION PRICES

Four different prices can be set for each selection according to the programmed time bands for when the time table option is set.

For each of the 4 time bands prices (0 to 65,535) can be programmed globally (same price for all selections) or for the single selections.

Should the majority of products be sold at the same price, it will be convenient to set the price globally and then change the figure of the selections with different prices.

TIME BANDS

Four programmable time bands are provided for selling products at different prices.

The time periods are programmable for beginning and end time by hours (00 to 23) and minutes (00 to 59).

If the values for start and end of the time band are set to 00.00 the time period is disabled.

The reference time is kept by an internal clock, programmable as:

day/month/year week-day 1-7

and then

hour/minutes/seconds.

COIN MECHANISMS

It is possible to decide which of the payment system protocols available are to be enabled for the functions.

The available payment systems are:

- Executive
- Validators
- BDV
- MDB

By selecting one of the systems it is possible to control its functions.

EXECUTIVE

The following payments systems are available for the Executive system:

- Standard
- Price Holding
- Coges
- U-Key

VALIDATORS

When the "Validat. Lines" (line setting) function of the "technician" menu is displayed, the value of the 6 validator coin lines, A to F, can be changed.

BDV

The BDV protocol menus are used for defining the following functions:

Type of vending

Setting the operating mode for multiple or single dispensing. With multiple dispensing, the change is not automatically returned after a successful selection, however the credit is available for further selections. When pressing the coin return button, the available credit is returned if its value is lower than the maximum change value.

Change control

This function enables/disables the return of credit if no selections are made.

If enabled, this function allows the return of coins even if the first selection was not dispensed.

If however a selection fails for any reason, the change will be returned if requested.

Maximum credit

This function is used to define the maximum accepted credit.

Maximum change

It is possible to set a limit to the total amount of change returned by the coin mechanism when pressing the coin return button or after a single dispensing serving.

Any credit exceeding the amount programmed with this function will be cashed.

Accepted coins

It is possible to define which, among the coins recognised by the validator, are to be accepted.

Check the label on the coin mechanism for the correct coin to value matching, indicating the position of the coins.

Not accepted coins

This function programs the rejection of coins when in "exact amount" mode.

Check the label on the coin mechanism for the correct coin to value matching, indicating the position of the coins.

Dispensing buttons

This function enables or not the buttons on the coin mechanism used to release the coins in the change return tubes.

Value of "exact amount"

This value defines the combination of empty coin tubes, setting the coin mechanism in "exact amount" mode. The possible combinations of empty coin tubes are indicated below.

For greater simplicity, the combination is described with reference to tubes A, B and C, where tube A receives the lower value coins and tube C the greater value coins.

0	=	A or (B and C)
1	=	A and B and C
2	=	A and B only
3	=	A and (B or C)
4	=	A only
5	=	A or B (default) only
6	=	A or B or C
7	=	A or B only
8	=	A or C only
9	=	B and C only
10	=	B only
11	=	B or C only
12	=	C only

C.P.C. device

It dialogues with the coin mechanism if devices are installed or removed from the serial interface (C.P.C.-type devices - the monitoring unit is always enabled by default).

Minimum level of tubes

It brings forward the "Insert exact amount" message for the user, by adding a number of coins between 0 and 15 to the programmed number of coins, to set the "full change tubes" status.

Free Vend VMC

Most payment systems with the BDV protocol control the free vend function.

However, there are some payment systems without such function.

In this case, if free selections are to be dispensed, free vending must be enabled with VMC (vending machine control, enabled by default) and the price of the selections must be set to zero.

MDB

The MDB protocol menus are used for defining the following functions:

Type of vending

Setting the operating mode for multiple or single dispensing. With multiple dispensing, the change is not automatically returned after a successful selection, however the credit is available for further selections. When pressing the coin return button (if the function is enabled), the available credit is returned up to the maximum change value.

Change control

To enable/disable the operation of the coin return button.

Maximum credit

This function is used to define the maximum accepted credit.

Maximum change

It is possible to set a limit to the total amount of change returned by the coin mechanism when pressing the coin return button or after a single dispensing serving.

Any credit exceeding the amount programmed with this function will be cashed.

Accepted coins

It is possible to define which, among the coins recognised by the validator, are to be accepted when the change tubes are full.

Check the coin mechanism configuration for the correct coin to value matching.

Returned coins

It is possible to define which, among the coins available in the tubes, are to be used for returning the change. This parameter is active only with coin mechanisms that do not automatically control the choice of tube to be used (Auto changer payout).

Check the coin mechanism configuration for the correct coin to value matching.

Accepted bills

It is possible to define which, among the bills recognised by the reader, are to be accepted.

Check the reader configuration for the correct bill to value matching.

Minimum level of tubes

This function is used for setting the number of coins (0 to 15) to determine the status of full change tubes and the "Insert exact amount" message for the user.

Accepted coins with "exact amount"

It is possible to define which, among the coins recognised by the validator, are to be accepted when the machine is in the "exact amount" condition.

Check the coin mechanism configuration for the correct coin to value matching.

Accepted bills with "exact amount"

It is possible to define which, among the bills recognised by the acceptor, are to be accepted when the machine is in the "exact amount" condition.

Check the acceptor's configuration for the correct bill to value matching.

COMMON FUNCTIONS

Other menus are available, common to the three protocols, used for defining the following functions:

IMMEDIATE CHANGE

Normally, the amount of credit inserted for a selection is cashed after the machine sends the message "Selection successful".

When this function is enabled, disabled by default, the cash message is sent at the beginning of dispensing.

DECIMAL POINT

Press the confirm button "↵" to display the position of the decimal point, i.e.:

0	decimal point disabled
1	XXX.X
2	XX.XX
3	X.XXX

Press the confirm button "↵", these values will start blinking and can then be modified as necessary.

MASTER/SLAVE

The machine control system is pre-arranged for the connection in a bank of vending machines using special kits. This permits the use of a single payment system for more machines.

In the event of installation in a bank of machines, it can be configured a "Master", i.e. having control over the second machine, or as "Slave", i.e. leaving the control to the other machine.

Although the machine can be used in either the master or slave functions, it is advisable to use the Snakky as master, thus taking advantage of the central push-button panel and the easier opening of the doors.

The master/slave function is not enabled by default.

To enable the function, it must be defined which machine is master and which one is slave in the software of both the Snakky and the Astro.

If an Executive payment system in "Price Holding" mode is set in the master machine, the information must be set also in the software of the slave machine.

The payment system of the slave machine must always be defined as "validator".

In the event of failed electrical connection, both machines will display the message "failed communication".

COMBINED SELECTIONS

A combined selection is intended as the association of two selections, one from the Snakky and one from the Astro, to the same number (85 to 89) sold at a single price.

Since a numeric keypad is required for setting and controlling the combined selections, the relevant menu is included only in the software of the Snakky permitting the combination of a selection from the keypad (10 to 79) with a direct selection (01 to 18).

Combined selections can be used either with the Snakky as master and Astro as slave (recommended configuration) or vice versa. If one of the two selections is not available, the combined selection is not dispensed. If the immediate change option is not activated on the master machine, and the first selection fails, the whole amount is returned. If the second selection fails, it will be possible to decide whether to keep or return the entire amount by activating/deactivating the "Virtual change return" option.

FREE VEND BONUS

This function, compatibly with the national laws, permits the dispensing of a free product every certain programmable number of sold selections. In any case the free selection is random within the programmed number. The machine emits an intermittent sound signal and the display indicates the message "FREE selection".

SPIRALS/SELECTIONS

This set of functions is used to define the selection control parameters.

MACHINE CONFIGURATION

This function is used to detect and store the number and position of the trays and of the selection motors.

VIRTUAL SELECTIONS

This function is used to define a pair of selections that can be sold at a price different from the sum of the two selections, using a single selection number. 5 virtual selections can be programmed (80 to 84).

RETURN OF VIRTUAL PRICE

This function is used to define, in the event of failed second dispensing in a virtual selection, not to cash the price of the second selection (only if an MDB payment system or validator are used). With other payment systems, it can be decided whether or not return the entire amount.

SELECTIONS WITH TWO MOTORS

In order to dispense long products, dividers can be fitted so that two motors are used for each single selection.

With this function the operation of two motors can be combined, specifying the selection number of the second motor.

The first motor number will be the selection number, while the selection number of the associated motor will remain disabled.

Important notice!

After a failure to the motors of these selections, the machine configuration procedure in the "Spiral/Selection" menu must be followed.

ROTATION SELECTIONS

With this function it is possible to create 7 groups of spirals with the same selection number that are activated by rotation, to increase the autonomy of the same product and make dispensing uniform.

The grouped spirals of a single selection must be next to each other.

All selections belonging to the same group must have the same price.

For correct safety management of the selections it is advisable that also a dispensing detection device be installed in the machine.

PRODUCT CODE

This function is used for assigning a 4-digit identification code to each selection for processing the statistics.

DIRECT SELECTIONS

The vending machine can be fitted (as standard feature or as optional according to the model) with a 5-button keypad to which allocate a group of selection.

After enabling the direct selection function, it will be possible to allocate a group of selections to each key by specifying the start and end numbers of the series. The selections, as long as in a sequence, can be also from different trays. The products are dispensed alternating from each of the spirals that are grouped in a direct selection.

All selections belonging to the same group must have the same price.

For correct safety management of the selections it is advisable that also a dispensing detection device be installed in the machine.

PHOTOCELL PARAMETERS

The vending machine can be fitted (as standard feature or as optional according to the model) with a device that, by means of photocells, detects the passage of dispensed products.

When this device is installed, the following can be monitored:

- Error before dispensing; when at the selection start the photocell beam is not read.
- Error after dispensing; when the motor fails during dispensing.
- Error for no product; when the device does not detect the passage of a product during dispensing.

In these cases the machine can be programmed to:

- set a rotation time for each spiral for settling beyond the normal rotation;
- return or not the paid amount;
- block further selections for the involved spiral.

DISPENSING COMPARTMENT LOCK PARAMETERS

The dispensing compartment can be fitted (as standard feature or as optional according to the model) with a lock device.

This function is used for deciding whether leaving the dispensing compartment “always free” or “unlock it with dispensing”.

In “unlock with dispensing” mode the dispensing compartment hatch is unlocked only for a certain period of time, programmable at between 1 and 10 minutes, after each product selection. In this case it is possible to enable the function that places the vending machine out of service for a certain period of time, programmable at between 1 and 10 minutes, if the dispensing compartment hatch stays open.

The machine is placed out of service if the lock device is always closed during dispensing.

REFRIGERATION PARAMETERS

The operation of the refrigeration system can be programmed for the following functions.

TEMPERATURE

The machine internal temperature during normal operation can be set directly in °C (5° to 20°C, 8°C by default). The temperature differential deviation defined with the previous function for starting/stopping the cooling unit is 2°C.

DEFROSTING

This function allows for a defrosting cycle (switching the cooling unit off, regardless of the temperature) of 20 minutes. The time interval between cycles can be programmed from 0 to 99 hours (set to 6 hours by default); the time interval will be determined according to the relative humidity and the frequency of door openings.

With the timing set to 0 the function is disabled.

ENABLE COLD UNIT

The cooling unit operation can be disabled. The change will apply when restarting the machine.

FOOD CONTROL

This function is not active in this model.

TEMPERATURE LOG

The internal temperature is stored every 10 minutes. With this function, it is possible to read the date, time and stored temperature.

DISPLAY

This set of functions is used to manage the messages indicated on the external display.

LANGUAGE

There is an option of language, selected among the available ones, to be used for the messages on the display.

DISPLAYING MESSAGES FOR THE USER

It is possible to choose the kind of information to be indicated on the display during normal operation.

The following information can be displayed:

- Internal temperature
- Time

It is possible to choose the language for the displayed messages.

PROMOTIONAL MESSAGE

Enable

When in this menu, press the confirm button “**↵**” to display the status of the message (enabled or disabled). The status can then be changed using the “**↑**” and “**↓**” buttons.

Setting

The 2-line message can be written using the “**↑**” and “**↓**” buttons to scroll through the available characters.

Press the confirm button “**↵**”, the first character will start blinking and can be modified.

The message is stored by pressing button “**←**”.

CUSTOMISING THE MESSAGES

The machine uses standard messages to give information to the user during normal operation (e.g. “Ready”, “Take” etc.). When this function is enabled, the message can be changed in the same manner as setting the promotional message. Changes are stored as copies of the standard messages.

Therefore, if this function is disabled, the standard messages will be displayed again, but the changed messages are still stored.

DISPLAY THE SELECTION COUNTERS

This function is used to enable/disable the display of the total number of sales since the last statistic reset, during the start-up phase of the machine.

LCD CONTRAST CONTROL

This function is used for adjusting the display contrast from 5% to 99% (default).

MISCELLANEOUS

This set of functions contains some sub-menus, used less frequently, which permit control of the functions described below.

PASSWORD

ENABLING THE PASSWORD

This function is used to enable the option of requesting the password to access the technician menu; the password request is disabled by default.

ENTERING THE PASSWORD

It is a 5-digit numeric code which is required to access the technician menu.

The default value of this code is set to 00000.

DISPLAYING THE FILLER MENU

This function is used to determine the filler menu options to be left active or to be disabled (ON/OFF):

- Statistics
- Single selection prices
- Change tubes control
- Special selections
- Test
- GSM connection
- EVADTS

The reference numbers of the menus do not change even if some are disabled.

STATISTICS

Data on the machine operations is stored in both general counters and relative counters, which can be reset without losing total data.

PRINT

Connect an RS232 serial printer having a Baud rate of 9600, 8 data bit, no parity, 1 stop bit to the serial port located on the push button board to print all of the statistics, and namely:

Total

- 1 - counter by single selection;
- 2 - counter by time bands;
- 3 - failure counter;
- 4 - coin mechanism data;
- 5 - photocell errors;
- 6 - motor errors;

Relative

- 1 - counter by single selection;
- 2 - counter by time bands;
- 3 - failure counter;
- 4 - coin mechanism data;
- 5 - photocell errors;
- 6 - motor errors;

The hardcopy printout will also contain the machine information, and namely:

- date/time of print
- machine name
- software version
- operator code
- machine code
- Installation date.

To connect the printer, do as follows:

- press the confirm print button "↵", displaying the message "Confirm?";
- connect the printer before confirming;
- press the confirm button "↵" to start printing.

DISPLAY

When pressing the confirm button "↵" the data described in the paragraph "Printing the statistics" is sequentially displayed.

RESETTING THE STATISTICS

Statistics can be reset for counters globally (all types of data) or selectively for:

Total

- selections
- failures
- coin mechanism data
- photocell errors;
- motor errors;

Relative

- selections
- failures
- coin mechanism data
- photocell errors;
- motor errors;

Press the confirm button "↵", and the message "Confirm?" starts blinking.

Press the confirm button "↵", the message "Working" is displayed for a few seconds and all statistics are reset.

N.B.: when resetting the total statistics also the relative statistics are reset.

BDV protocol Audit

The information regarding the coin mechanism indicates the actual currency of:

Audit 1 Money in the tubes
Money present in the change tube that moment

Audit 2 Money to the tubes
Money sent to the change tubes

Audit 3 Money to the box
Money sent to the coin box

Audit 4 Return of change
Total money returned

Audit 5 Dispensed money
Total money dispensed manually

Audit 6 Excess
Excess money. Extra amounts paid by the customer that were not returned (in the event there was no money available for return)

Audit 7 Total sales
Total value of sales

Audit 8 Exact change
Value of sales in the "no change" condition.

Audit 9 Mixed dispensing
Total value of dispensing paid differently; for example also other types of payment (C.P.C., token).

Audit 10 Manual filling
Money inserted in the coin mechanism through the manual filling function.

MDB protocol Audit

Audit 1 Money in the tubes

Money present in the change tubes that moment

Audit 2 Money to the tubes

Money sent to the change tubes

Audit 3 Money to the box

Money sent to the coin box

Audit 4 Change return

Total money returned

Audit 5 Excess

Excess money. Extra amounts paid by the customer that were not returned (in the event there was no money available for return)

Audit 6 Release of tubes

Value of coins dispensed with the "Tubes control" function

Audit 7 Filling tubes

Value of money cashed with the manual loading function

Audit 8 Cash sales

Value of total sales with cash money (coins + bills)

Audit 9 Cashed bills

Value of cashed bills

Aud. 10 Charge key

Value of money changed into the key

Aud. 11 Sales with key

Value of money cashed for dispensing with key

Audit. 12 Money dispensed manually

Value of coins dispensed manually with the dispensing buttons on the coin mechanism.

TEST

SELECTIONS

This function is used to simulate the normal dispensing of products without inserting any money.

Check the functioning of the motor rotation by pressing the selection buttons.

MOTOR TEST

It activates all motors in a sequence.

AUTOTEST

A function to check, in a semiautomatic manner, the correct operation of some devices is implemented in the software.

Some checks occur automatically, others need the manual operation of the monitored component; button "➡" is pressed to go to the next check.

The monitored devices are:

"Keypad"

Press the button requested on the display; if it works correctly the request for the next button is presented.

"Temperature"

The value of temperature detected by the probe is displayed.

In the event of disconnection the value -11.0 is displayed.

In the event of a short-circuit the value 41.0 is displayed.

"←" to advance.

"Buzzer"

A series of sounds is emitted.

"Compressor"

The compressor is activated/deactivated using the "➡" and "←" buttons.

"Selections"

All selections are activated in a sequence.

"Coin mechanisms"

Checking that communication with the coin mechanism takes place correctly and which validator lines are set as being active.

"Photocells"

If the product detection device is present, the light beam reading and interruption are checked.

"Disp compt lock"

If the device for locking the dispensing compartment opening, use the "➡" and "←" buttons to lock and unlock the compartment opening.

"Direct keypad"

If fitted on the machine, the 5 buttons are checked sequentially.

Press the button requested on the display; if it works correctly the request for the next button is presented.

MACHINE INFORMATION

The machine can memorize a series of codes which will identify it when retrieving statistics.

More specifically the following can be stored:

- 6-digit operator code;
- 8-digit vending machine code which identifies the machine.

INSTALLATION DATE

This function is used to store the current date of system, if set correctly, as installation date.

The date is printed when retrieving the statistics.

MACHINE CODE

When the "Machine code" function is displayed the eight-digit numeric code identifying the machine can be changed (from the default 0).

OPERATOR CODE

When the "Operator code" function is displayed the six-digit numeric code identifying groups of machines can be changed (from the default 0).

INITIALISING

When the "Initialise" function is displayed the vending machine can be initialised, selecting the "country" (intended as configuration type) and the language, restoring all related default data.

This function should be used in the event of a memory data error or when the software version is replaced/updated.

All statistic information will be reset.

Press confirm button "↵"; the country and the language to be used are requested, then the message "Confirm?" is displayed. Press confirm button "↵" a second time and the message "Working" is displayed for a few seconds.

EVADTS CODES

The EVADTS (European Vending Association Data Transfer System) communication protocol has two codes for identifying the machine and for recognising the data transfer terminal:

PASS CODE

It is a four-digit alphanumeric code (0-9; A-F) that must be the same as the one in the data transfer terminal to allow its identification.

Press the confirm button "↵" and the code is displayed as "0000" regardless of the actual value; then press the change button "←" and the first digit will start blinking.

Using the scrolling buttons, its value can be changed (during the change operation the value becomes visible). Press the confirm button "↵" and the next digit starts blinking.

Press the confirm key "↵" after changing the fourth digit; the value is stored and the display indicates "0000" again.

SECURITY CODE

It is a further alphanumeric code for reciprocal recognition between machine and EVADTS terminal.

Programming works as in the "Pass" code.

Connection

This function places the machine in wait mode for connection to retrieve data.

EVADTS CONNECTION

When activating this function, the machine awaits the connection with a device to acquire the EVADTS statistics.

GSM

The control software can send, via GSM modem, a signal indicating a machine failure or an "ending product" "pre-alarm", after dispensing a programmable number of selections.

The machine is pre-set to handle 7 pre-alarms.

The first five can be associated to spirals and the last 2 to trays.

PIN CODE

This function is used for programming the identification code that will be sent to the GSM modem (optional) when switching the machine on.

SETTING THE THRESHOLDS

This function is used for defining the number of pieces after which a "ending product" pre-alarm is signalled via modem.

RESETTING THE COUNTERS

With this function the counters that control the pre-alarms are reset.

THRESHOLD ASSOCIATION

This function is used for defining which spirals or trays to associate to "pre-alarms" for "ending product".

By associating spiral 10 to pre-alarm N. 1 and setting the threshold to 10 units with the "threshold setting" function, dispensing the tenth product from spiral 10 will generate a pre-alarm N. 1.

By associating tray N. 5 to pre-alarm N. 6 and setting the threshold to 30 units with the "threshold setting" function, dispensing the thirtieth product from tray 5 will generate a pre-alarm N. 6.

MACHINE BANK NUMBER

The number in the bank of machines (1 to 7) that identifies the

machines that have the "slave GSM" function, therefore sending data of the "master" machine via modem.

The number 0 identifies the machine that is connected directly to the modem, i.e. the "master GSM".

Chapter 3 MAINTENANCE

The maintenance operations described in this chapter should be carried out with the machine energised and therefore by qualified personnel, who are trained in the correct use of the machine and are aware of the specific risks of such condition.

To energize the system with the open door, simply insert the special key into the switch on the payment system compartment door (see Fig. 24).

Inside the machine, the only parts that stay energised are those protected by covers and carrying a plate with the warning “Disconnect the power before removing the protective cover”.

Before removing such covers disconnect the machine from the power grid.

The integrity of the machine and compliance with the standards of the relevant systems must be checked at least once a year by qualified personnel.

PRINTED BOARD FUNCTIONS AND INDICATOR LAMPS

The C.P.U. (Central Processing Unit) board controls all users set for the maximum configuration of the spiral compartment and processes the input signals from the keypad, the payment system and the cooling unit sensors. The card also houses some LEDs which, during the machine operation, give the following indications:

- Green LED (3): blinks during normal operation of the C.P.U. board;
- Yellow LED (4): glows when 5 V DC are detected;
- Red LED (7): glows when, for any reason, the software is reset.

CONFIGURING THE BOARD

This board is preset also for the MDB protocol.

The 4 dip-switches for setting the SW2 coin mechanism (see Fig. 17) should be set to OFF for Executive-BDV and to ON for MDB.

SOFTWARE UPDATE

The machine is fitted with a Flash EPROM which can be electronically updated.

By means of a special program and suitable system (UpKey, Personal Computer or similar) the machine management software can be updated without replacing the EPROM.

Warning!

When downloading the software it is advisable to disconnect the motor connectors from the CPU board (**J1 e J2**).

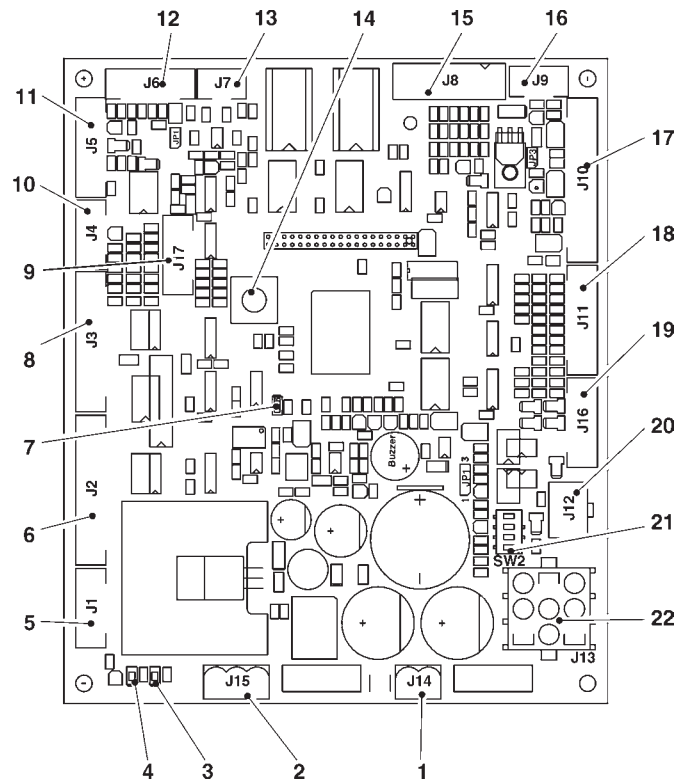

Fig. 17

- | | |
|----|---|
| 1 | - J14 Coin mechanism power supply |
| 2 | - J15 Board power supply |
| 3 | - Green LED: run (DL2) |
| 4 | - Yellow LED: 5 V DC (DL1) |
| 5 | - J1 Dispensing compartment connection |
| 6 | - J2 Spiral motor control |
| 7 | - Red LED: CPU reset (DL3) |
| 8 | - J3 Input/output |
| 9 | - J17 UpKey connection |
| 10 | - J4 Not used |
| 11 | - J5 RS232 |
| 12 | - J6 Photocells |
| 13 | - J7 Can-Bus |
| 14 | - Button not used |
| 15 | - J8 Validators |
| 16 | - J9 Probe |
| 17 | - J10 LCD display |
| 18 | - J11 Direct selection keypad |
| 19 | - J16 Keypad |
| 20 | - J12 MDB expansion |
| 21 | - Coin mechanism setting minidips (SW2) |
| 22 | - J13 Expansion for BDV / EXE |

CONFIGURING THE TRAYS

PRODUCT SPACERS

The spacers are used when loading “narrow” products. The spacers should be fitted to contain products, without blocking them, towards the right-hand side of the compartment, so that they stay upright. According to the type of products, assess whether it is more convenient to use the short or long side of the brackets and in which of the five adjustment notches to connect them. Pull the spacer towards the front to close the space and push it back to open the space. There must be at least 3 mm between the spacer and the products.

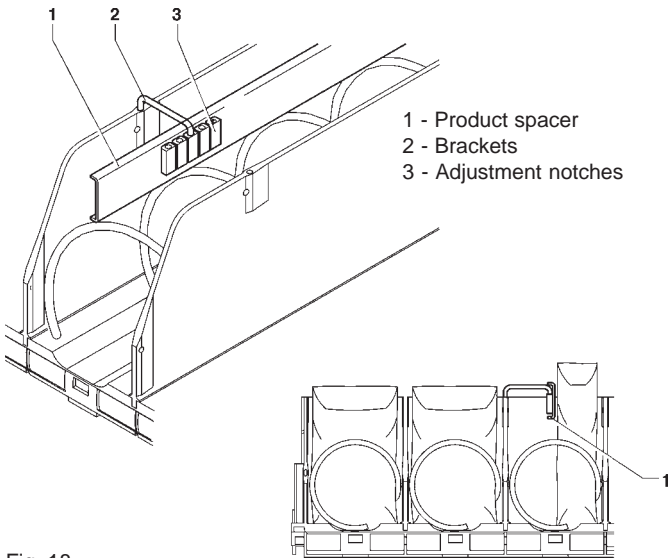

Fig. 18

PRODUCT EJECTOR

The ejectors, right-hand and left-hand, must be used for products packed in bags, such as potato crisps or similar. As they are hooked at the end of the spiral they push the products further out. If necessary slide the ejector along the spiral wire to locate the most appropriate position according to the product being dispensed.

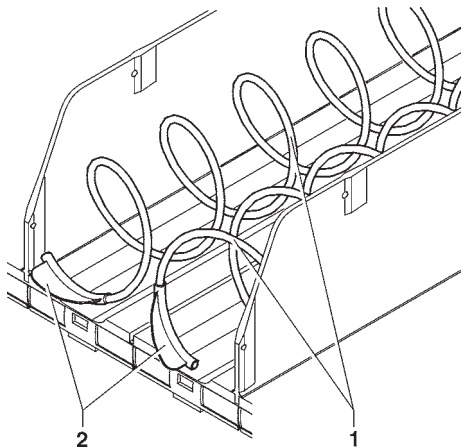

Fig. 19

1 - Spirals
2 - Ejectors

REPLACING THE SPIRALS

In order to change the number and the set-up of the product holders, proceed as follows:

- Slide out the concerned tray.
- Rotate the spiral in the opposite direction to the ejection rotation, holding the plastic support flange still, to separate the two parts and fit the other spiral.
- Fit the new spiral assembly proceeding in the opposite direction, ensuring that the spiral is positioned correctly

Fig. 20

1 - Spiral
2 - Plastic flange

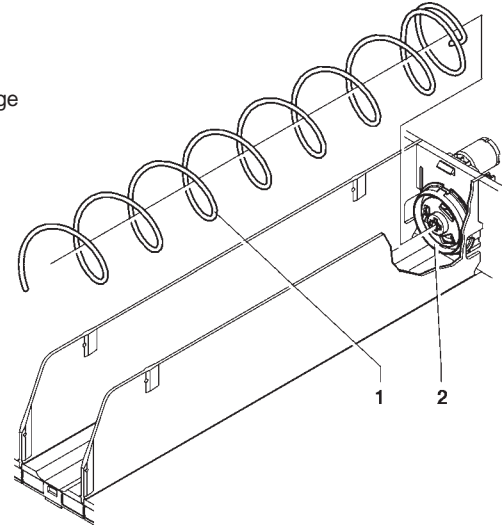

REMOVING THE TRAYS

To replace the trays proceed as follows:

- Slide out the tray to be modified;
- remove the electrical connector from the tray;
- lift the tray to unblock the retaining slide.
- To fit a new tray, proceed in the opposite way.

Fig. 21

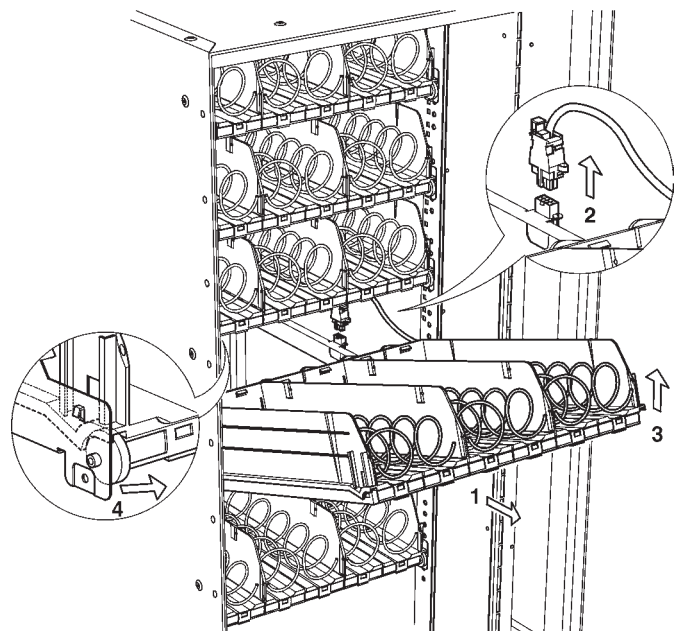

CHANGING THE NUMBER OF TRAYS

The vending machines are supplied with 7 trays. It is however possible to bring the number of trays to 5 or 6, proceeding as follows:

- Disconnect the plug from the power supply.
- Remove all trays from the machine.
- Move the guides (see Fig. 22) placed on the side supports, except the first ones at the bottom which stay in the same position.
- Remove the pair of guides not used.
- Replace the 5 or 6 trays, ensuring that the connectors are inserted properly.
- Secure the removed cables, as not to be in the way of other trays and cables.
- Reprogram the machine.

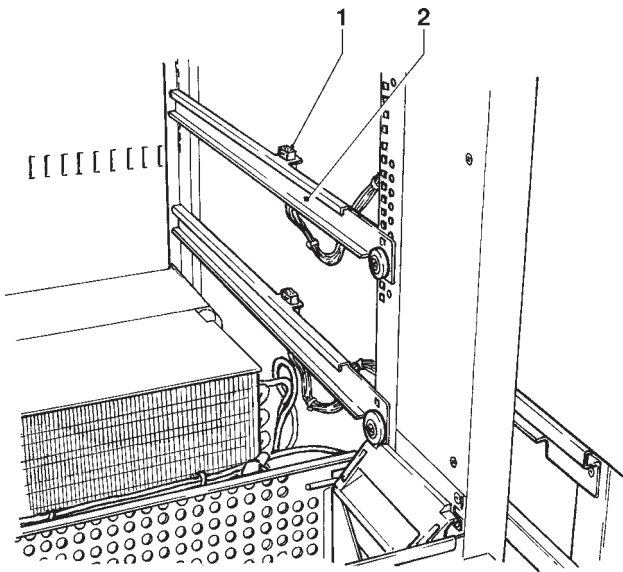

Fig. 22

- 1 - Tray connector
- 2 - Tray guide

CHANGING THE TRAY CONFIGURATION

The configuration of the spirals on each tray can be changed. To go from two selections with single spirals to one selection with double spirals, do as follows:

- Remove the tray to be modified.
- Remove the centre wall, pushing it towards the back and then lifting.
- Remove the spirals, and the flanges, from the two motors.
- Disconnect the left-hand side motor from the cable and remove it from the tray. In its place, fit the bush and pin bush.
- Install the right-hand and left-hand spirals with the same pitch onto the new flanges (right and left are identical), fitted with a cogged wheel, and then connect the right-hand one to the motor still on the tray and the left-hand one onto the previously installed bushes. The two cogged wheels must mesh.
- Remove the price labels and the product holders no longer used, and if necessary update the price labels still in use.
- Program the new selections with the desired price.
- Test the modified selections, to be sure of their correct operation.

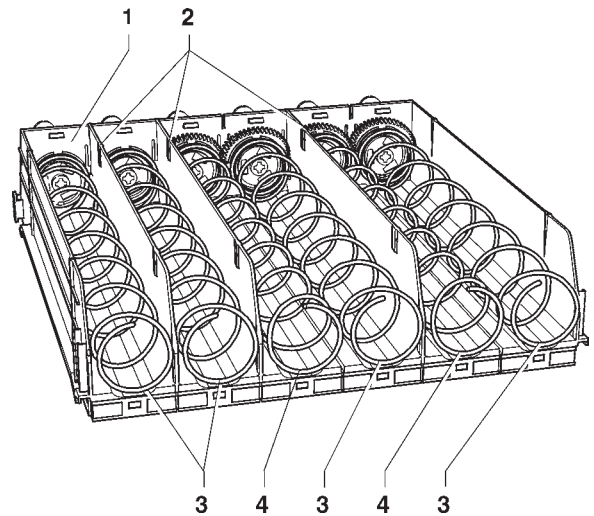

Fig. 23

- 1 - Tray
- 2 - Mobile walls
- 3 - Right-hand spiral
- 4 - Left-hand spiral

N.B.: The selection numbers are formed by two figures; the first figure refers to the tray number, counting from the top (1-6), the second figure refers to the spiral number, counting from the left (0-5).

The selection number to which the motor is connected will therefore be formed by the tray number plus the wire code number.

POWER SUPPLY UNIT

Fuses, switch and connectors positioned at the front of the power supply unit have the functions indicated below.

When replacing any fuses the power supply cable must be disconnected from the mains.

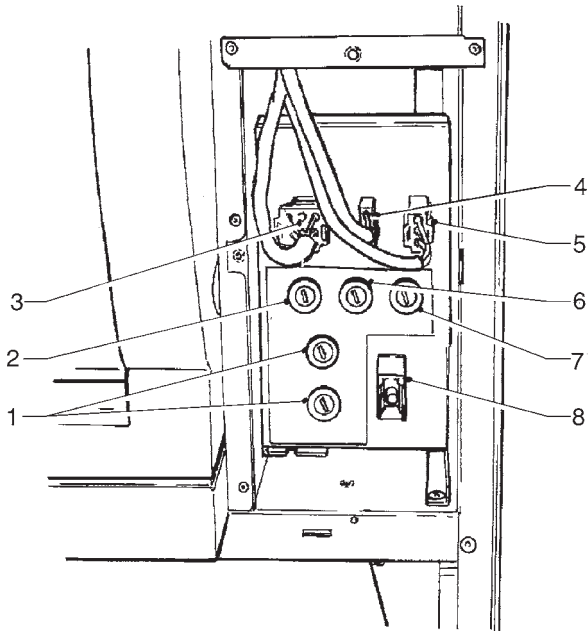

Fig. 24

- 1 Line fuses
- 2 Transformer primary winding protection fuse
- 3 CPU board power supply connector
- 4 Lamp connector
- 5 Compressor and fan connector
- 6 Transformer secondary winding protection fuse
- 7 Transformer secondary winding protection fuse
- 8 Payment system compartment switch

ACCESS TO THE COOLING UNIT

If for any reason the cooling unit need to be accessed from the machine, do as follows:

- remove the last tray
- remove the anti-theft grille
- undo the fastening screws from the product dispensing compartment and remove it
- For reassembly, proceed in the reverse order.

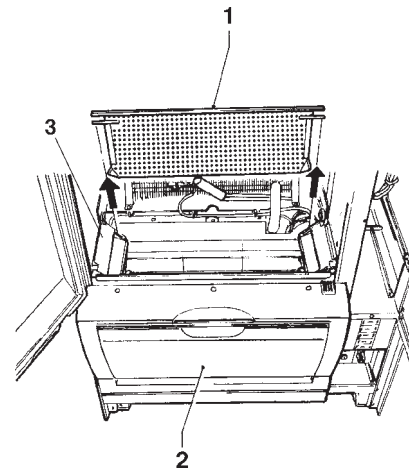

Fig. 25

- 1 Anti-intrusion grille
- 2 Dispensing compartment
- 3 Photocell support

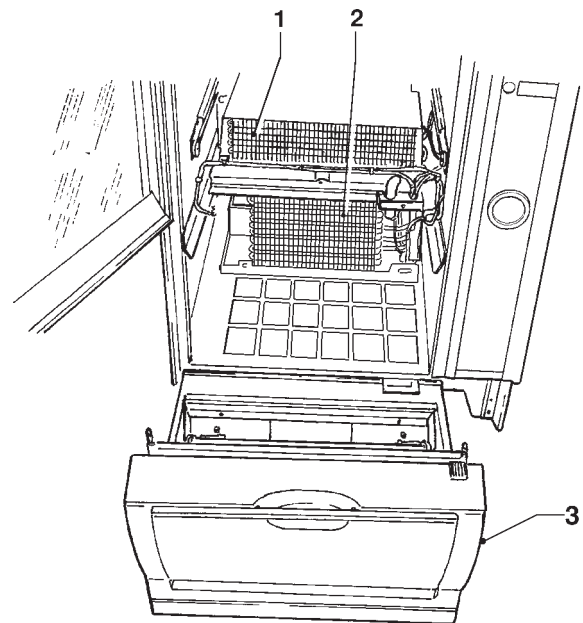
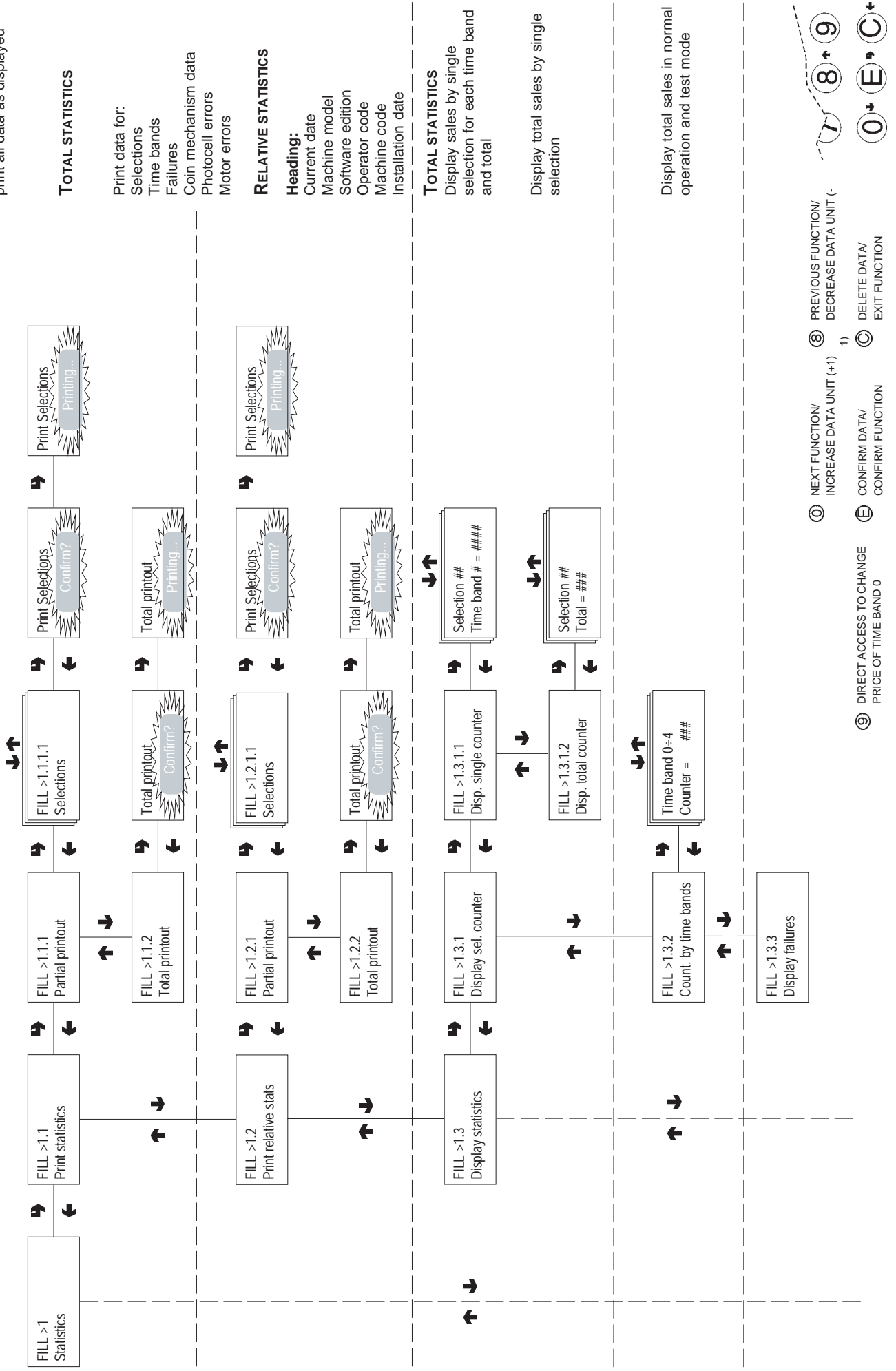

Fig. 26

- 1 Evaporator
- 2 Fan
- 3 Condenser
- 4 Dispensing compartment

Filler menu - Summary

With the printer connected
print all data as displayed



TOTAL STATISTICS

Print data for:
Selections
Time bands
Failures
Coin mechanism data
Photocell errors
Motor errors

RELATIVE STATISTICS

Heading:
Current date
Machine model
Software edition
Operator code
Machine code
Installation date

TOTAL STATISTICS

Display sales by single
selection for each time band
and total

Display total sales by single
selection

Display total sales in normal
operation and test mode

- ➡ NEXT FUNCTION/
INCREASE DATA UNIT (+1)
- ➡ PREVIOUS FUNCTION/
DECREASE DATA UNIT (-)
- ☑ CONFIRM DATA/
CONFIRM FUNCTION
- ✗ DELETE DATA/
EXIT FUNCTION
- ⓪ DIRECT ACCESS TO CHANGE
PRICE OF TIME BAND 0

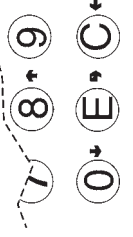

Filler menu - Summary

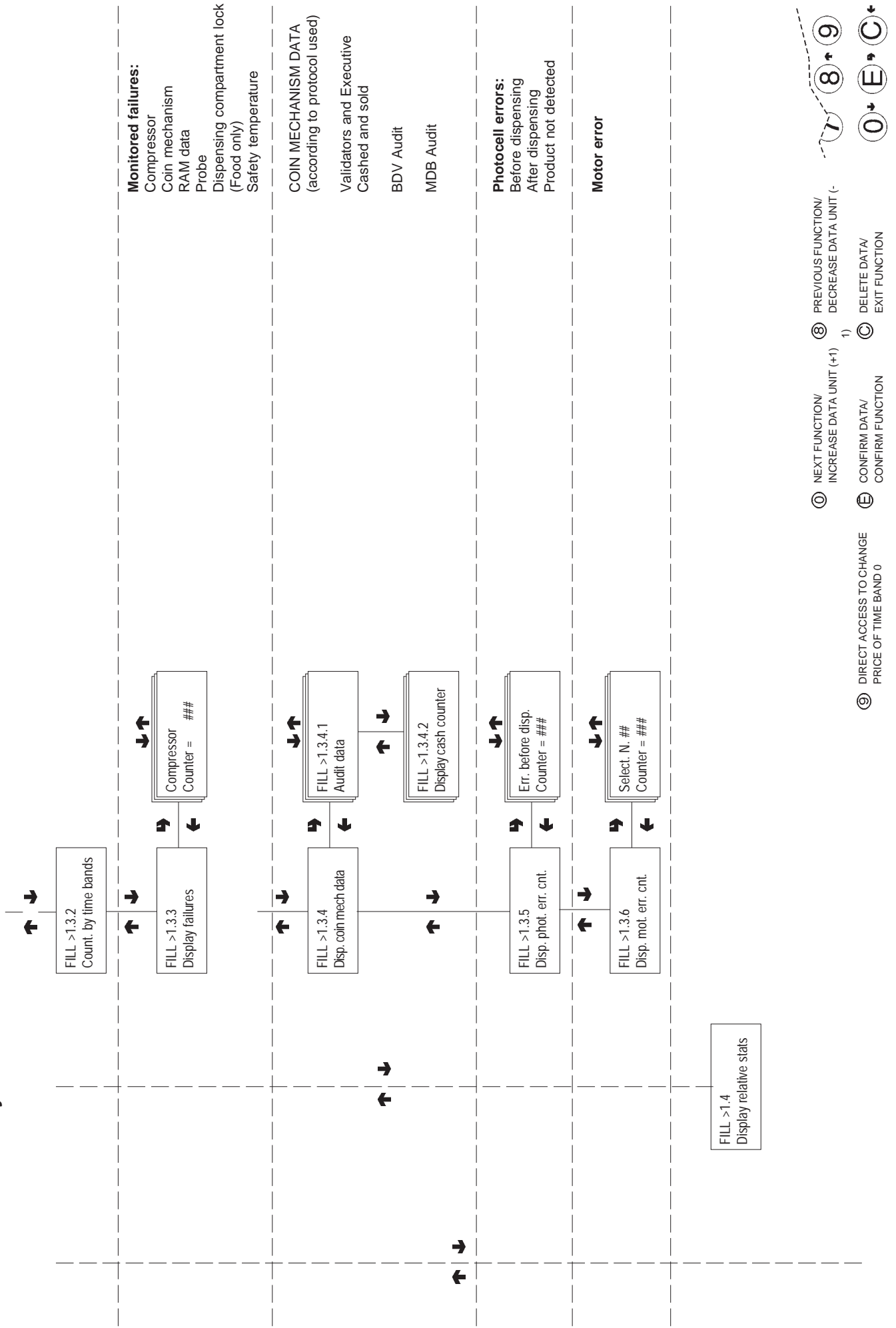

Filler menu - Summary

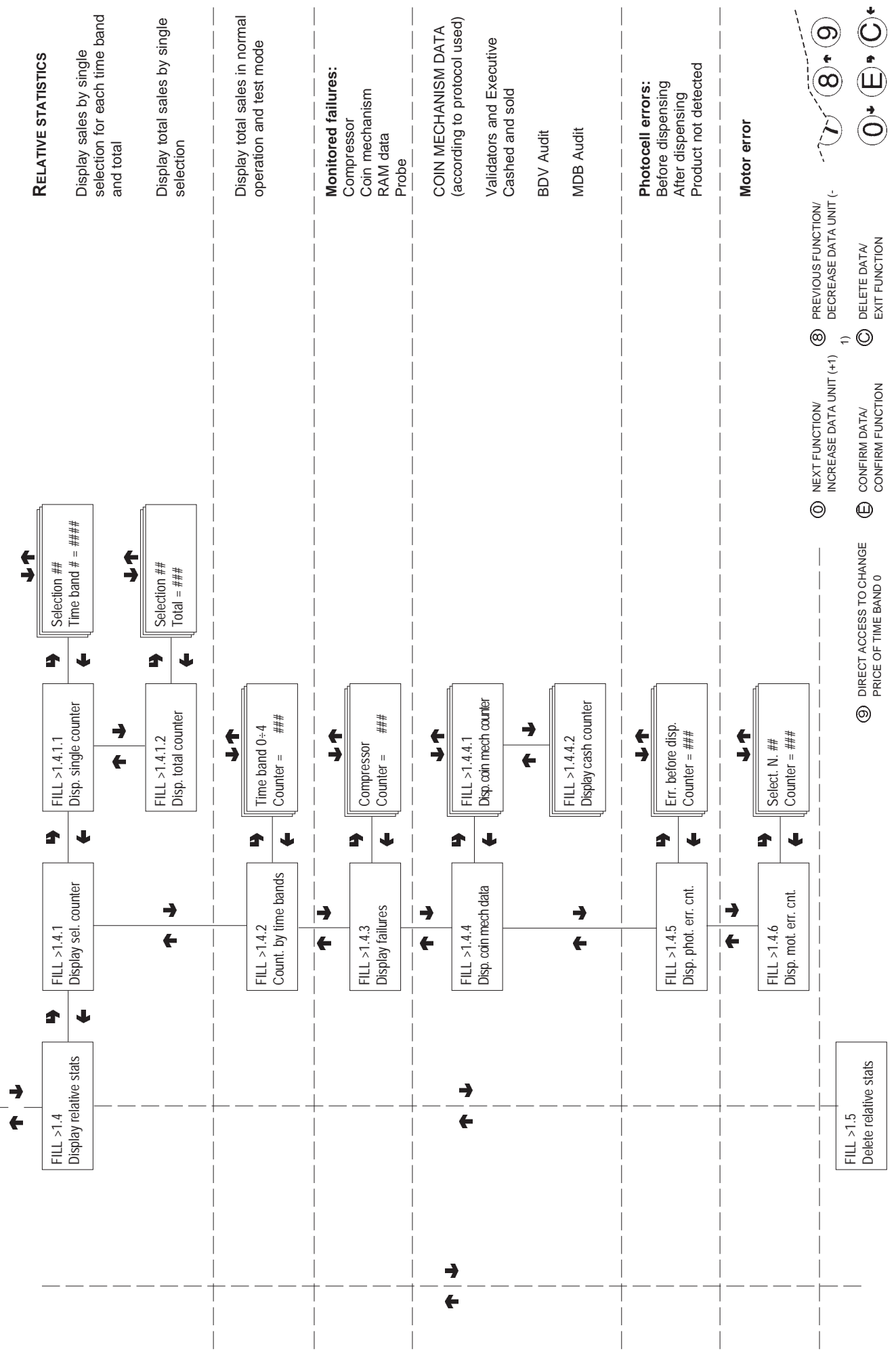

Filler menu - Summary

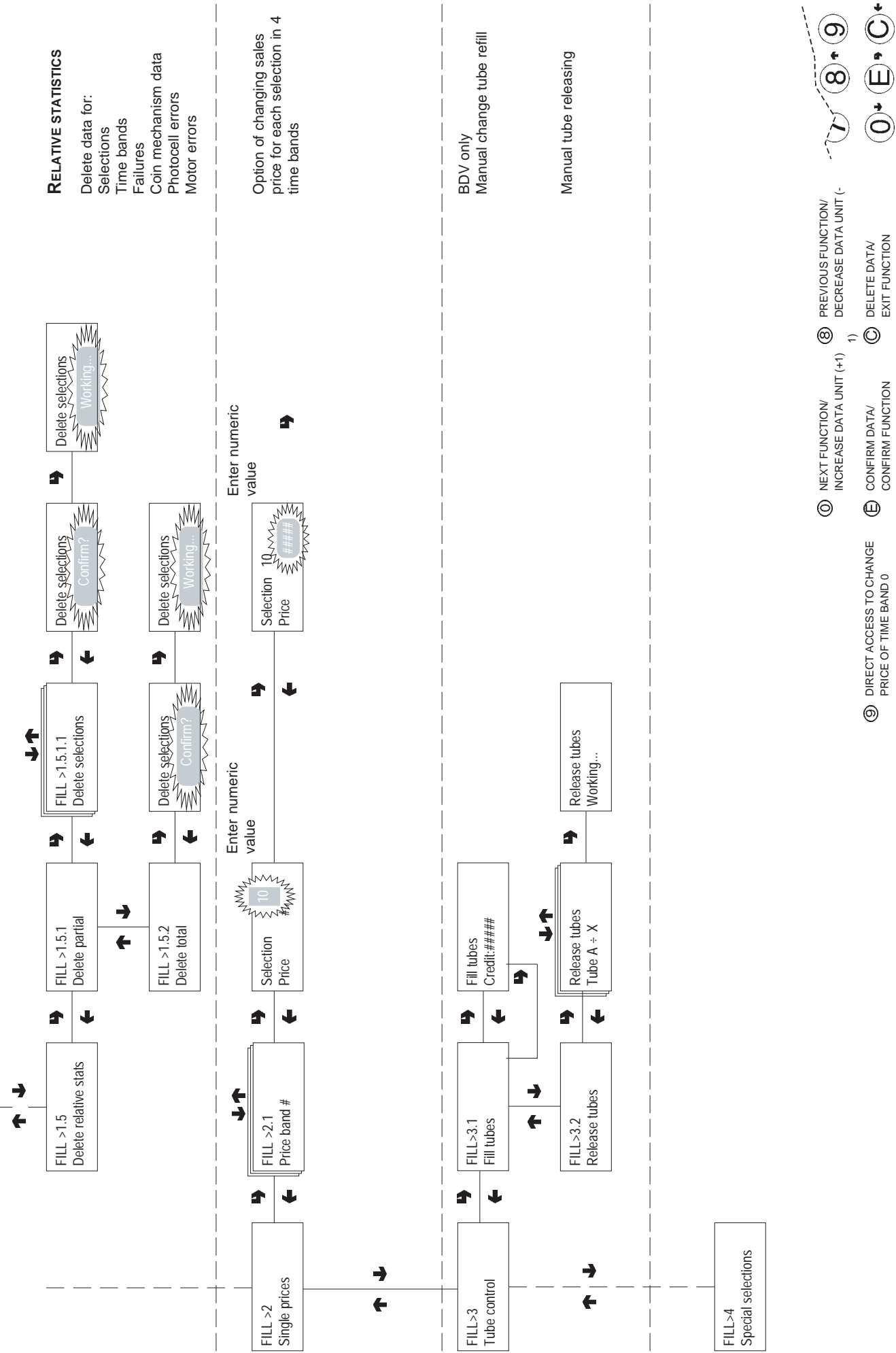

Filler menu - Summary

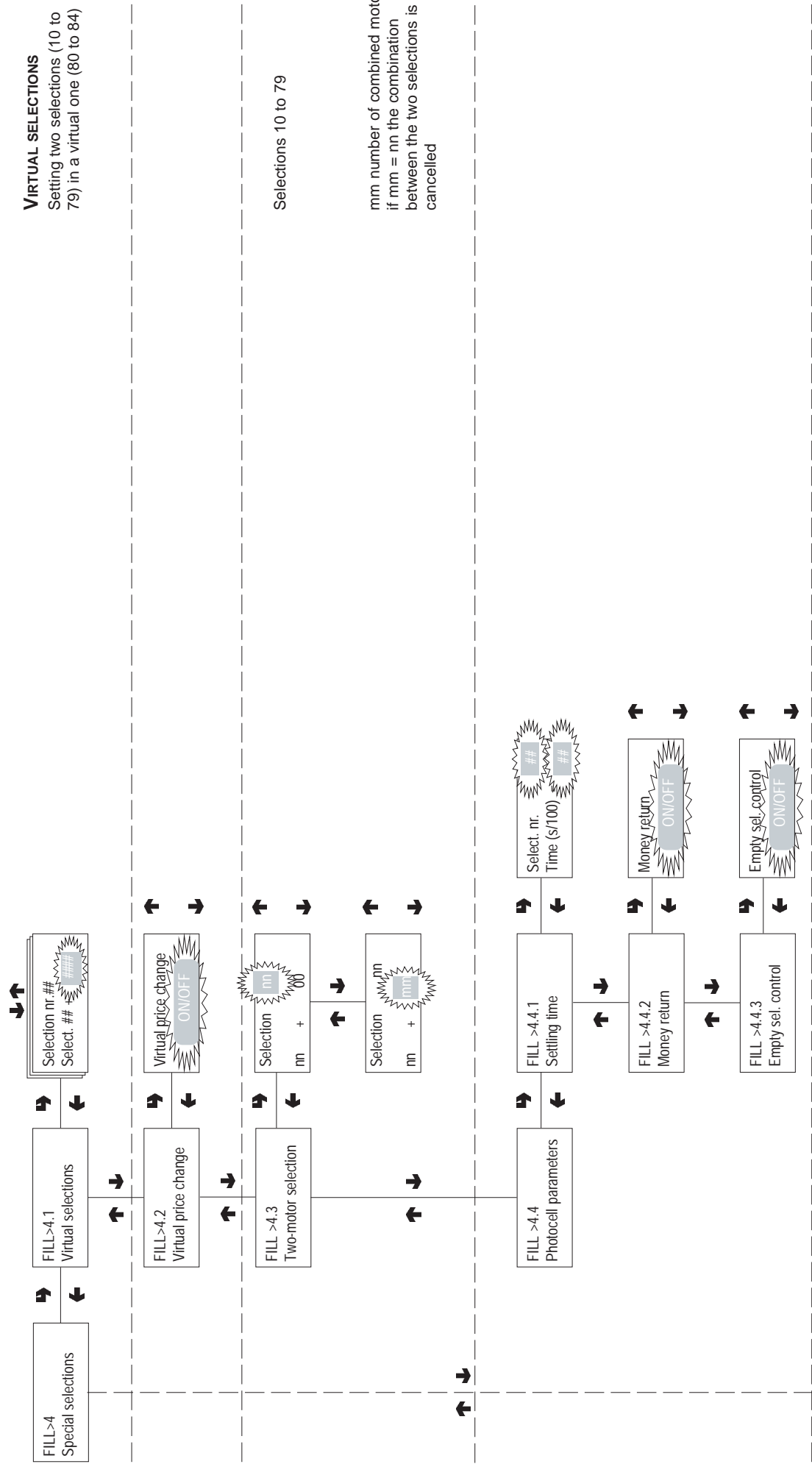

VIRTUAL SELECTIONS
Setting two selections (10 to 79) in a virtual one (80 to 84)

Selections 10 to 79

mm number of combined motor if mm = nn the combination between the two selections is cancelled

FILL>5 Test

- ⓪ NEXT FUNCTION/ INCREASE DATA UNIT (+1)
- ⓫ PREVIOUS FUNCTION/ DECREASE DATA UNIT (-)
- ⓬ DIRECT ACCESS TO CHANGE PRICE OF TIME BAND 0
- ⓭ CONFIRM DATA/ CONFIRM FUNCTION
- ⓮ DELETE DATA/ EXIT FUNCTION

Filler menu - Summary

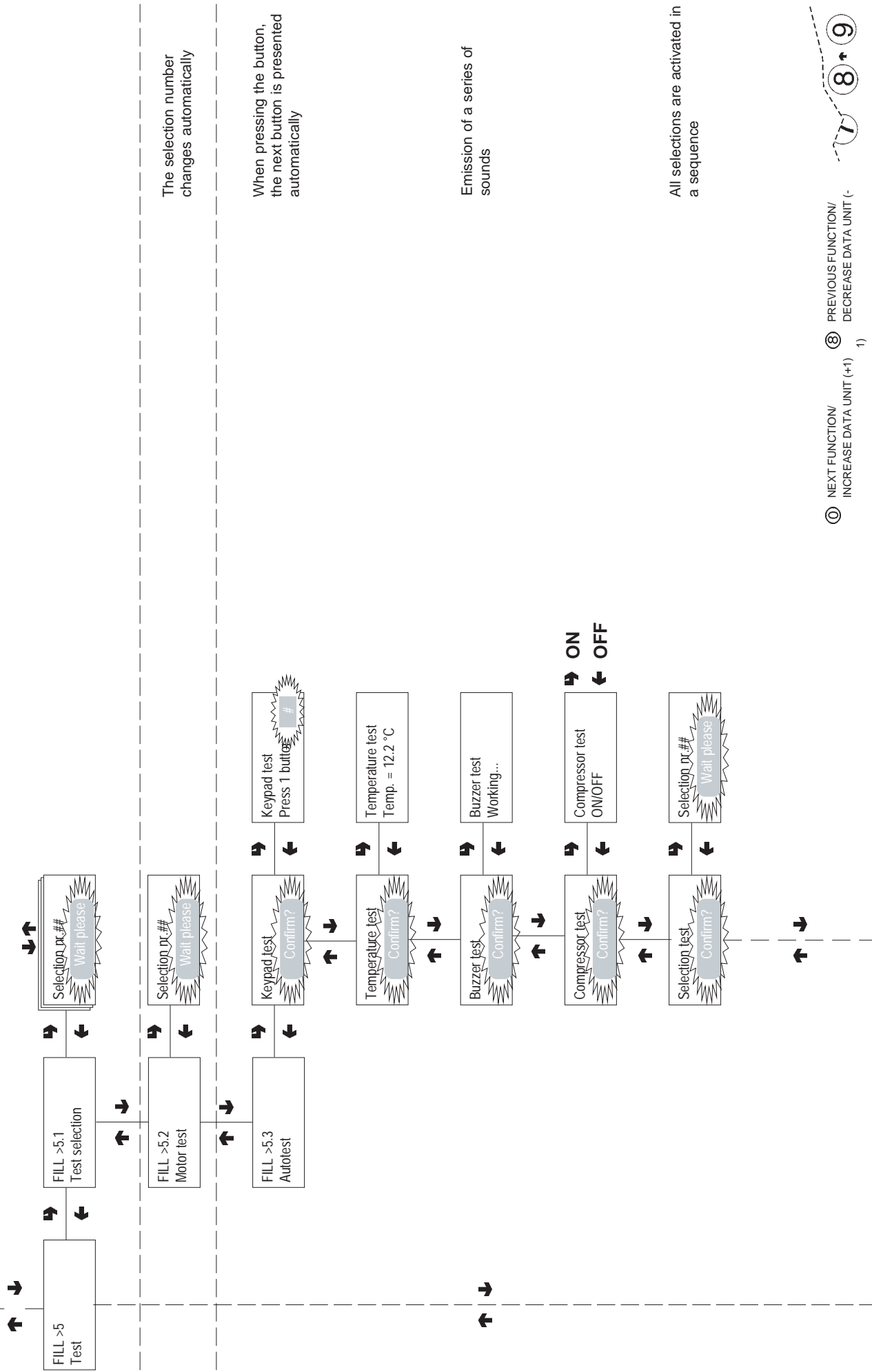

The selection number changes automatically

When pressing the button, the next button is presented automatically

Emission of a series of sounds

All selections are activated in a sequence

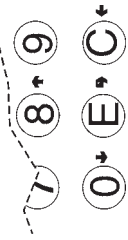

- ① NEXT FUNCTION/ INCREASE DATA UNIT (+1)
- ② PREVIOUS FUNCTION/ DECREASE DATA UNIT (-)
- ③ DIRECT ACCESS TO CHANGE PRICE OF TIME BAND 0
- ④ CONFIRM DATA/ CONFIRM FUNCTION
- ⑤ DELETE DATA/ EXIT FUNCTION

Filler menu - Summary

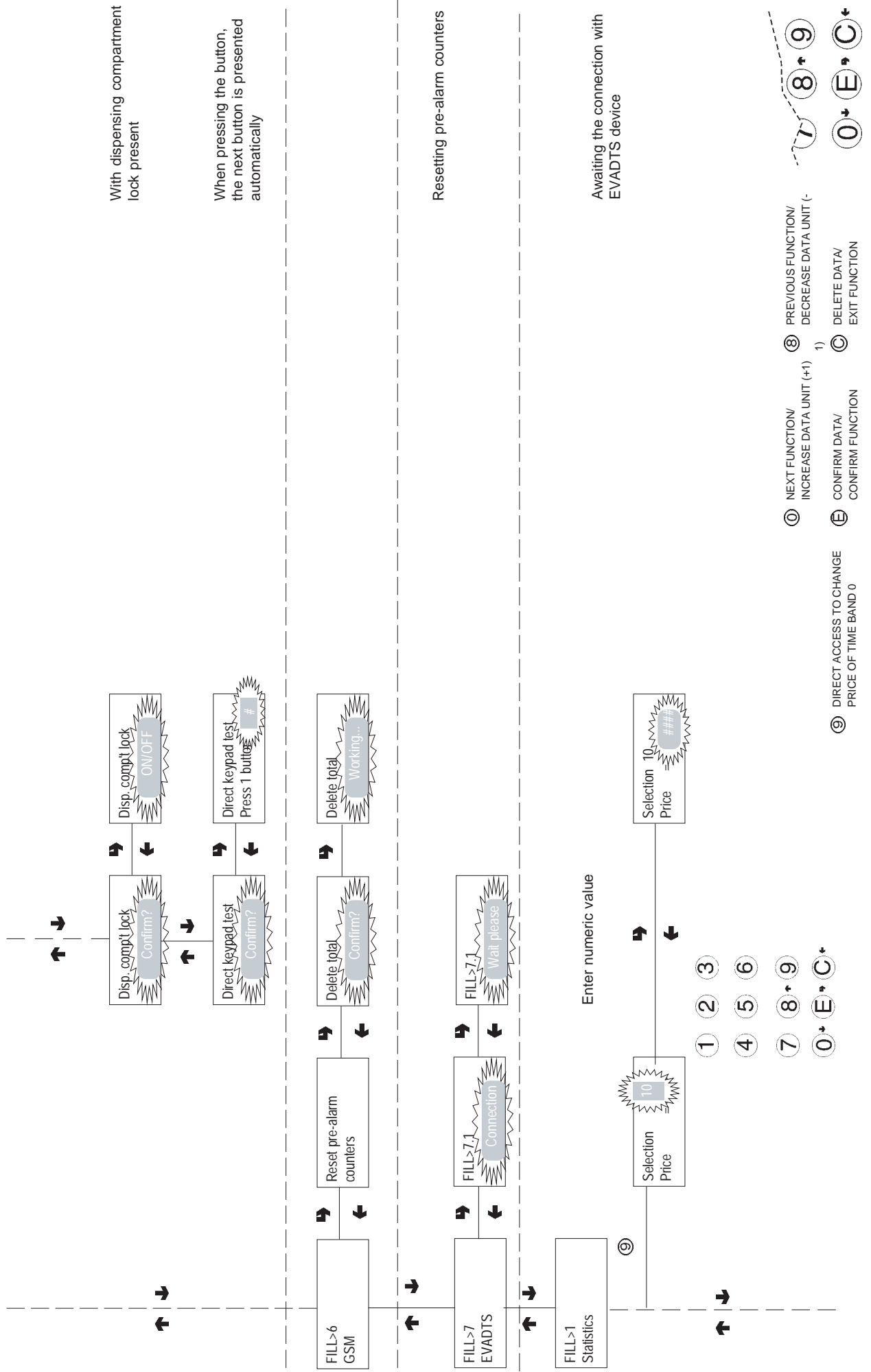

With dispensing compartment lock present

When pressing the button, the next button is presented automatically

Resetting pre-alarm counters

Awaiting the connection with EVADTS device

Technician menu - Summary

Time scrolling of present failures

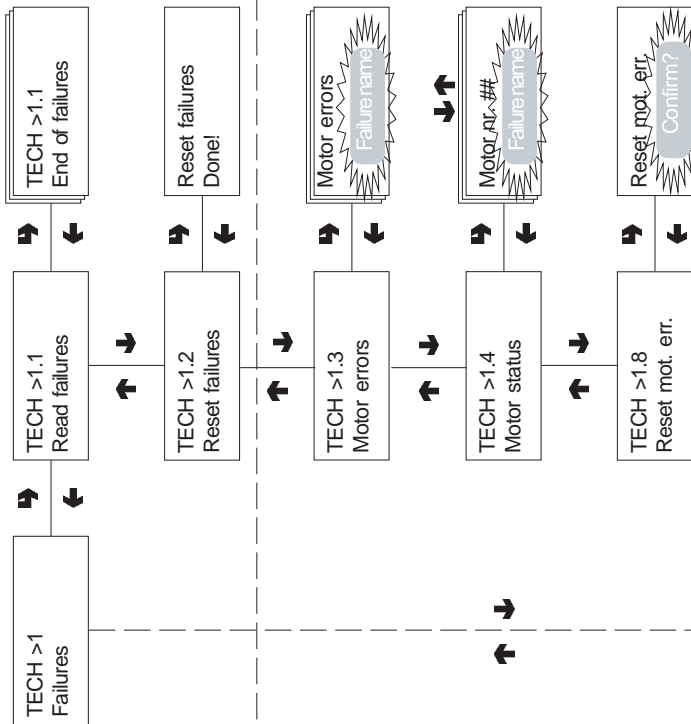

Time scrolling of present failures

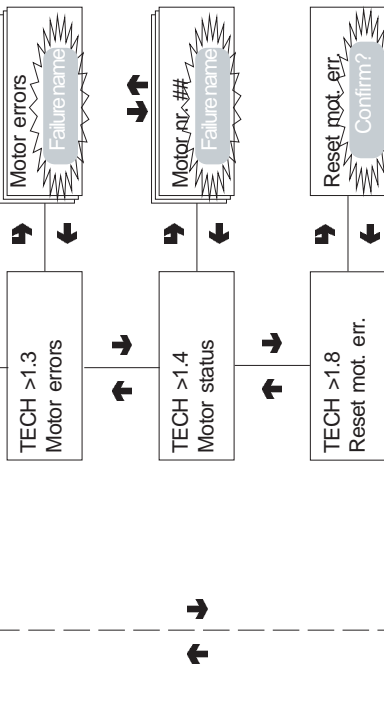

DISPLAYING FAILURES

Monitored failures:

- Compressor
- Coin mechanism
- RAM data
- Probe
- Dispensing compartment lock
- (Food only)
- Safety temperature

Possible motor conditions:

- OK
- Blocked
- Disconnected
- Not functioning
- Not present
- Empty selection

- ⊖ NEXT FUNCTION/
INCREASE DATA UNIT (+1)
- ⊕ PREVIOUS FUNCTION/
DECREASE DATA UNIT (-1)
- Ⓢ CONFIRM DATA/
CONFIRM FUNCTION
- Ⓣ DELETE DATA/
EXIT FUNCTION

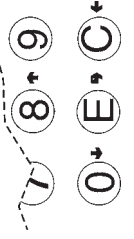

Technician menu - Summary

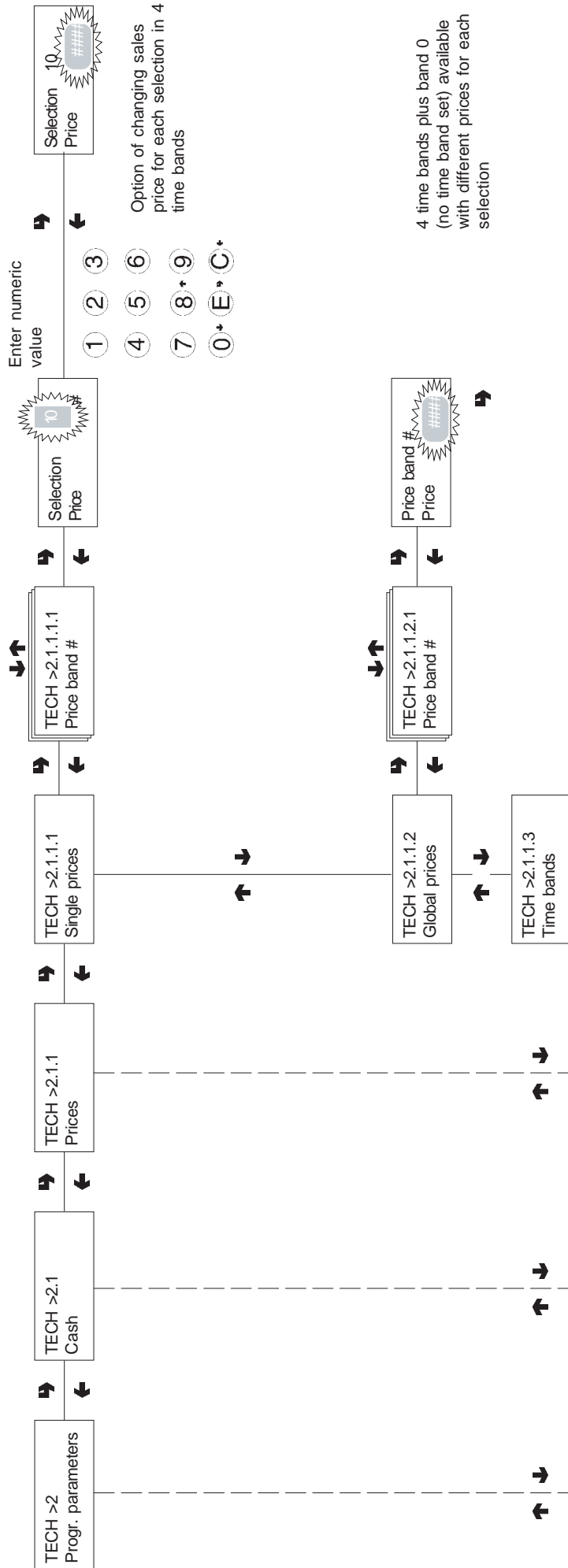

Option of changing sales price for each selection in 4 time bands

4 time bands plus band 0 (no time band set) available with different prices for each selection

- Ⓢ NEXT FUNCTION/ INCREASE DATA UNIT (+1)
- Ⓣ PREVIOUS FUNCTION/ DECREASE DATA UNIT (-1)
- Ⓤ CONFIRM DATA/ CONFIRM FUNCTION
- Ⓦ DELETE DATA/ EXIT FUNCTION

Technician menu - Summary

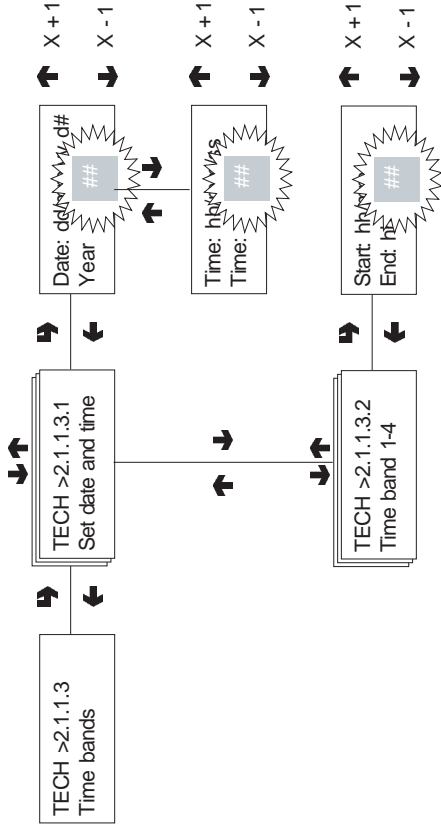

Clock

When confirming the blinking values, day, month, year and week day are entered one after the other. When confirming the week day hour and minutes are displayed, that can then be changed and confirmed.

TIME BANDS

When confirming the blinking values, hour and minute for start and end of time band are entered one after the other. When start and end of time band are set to 00:00 the bands are not activated.

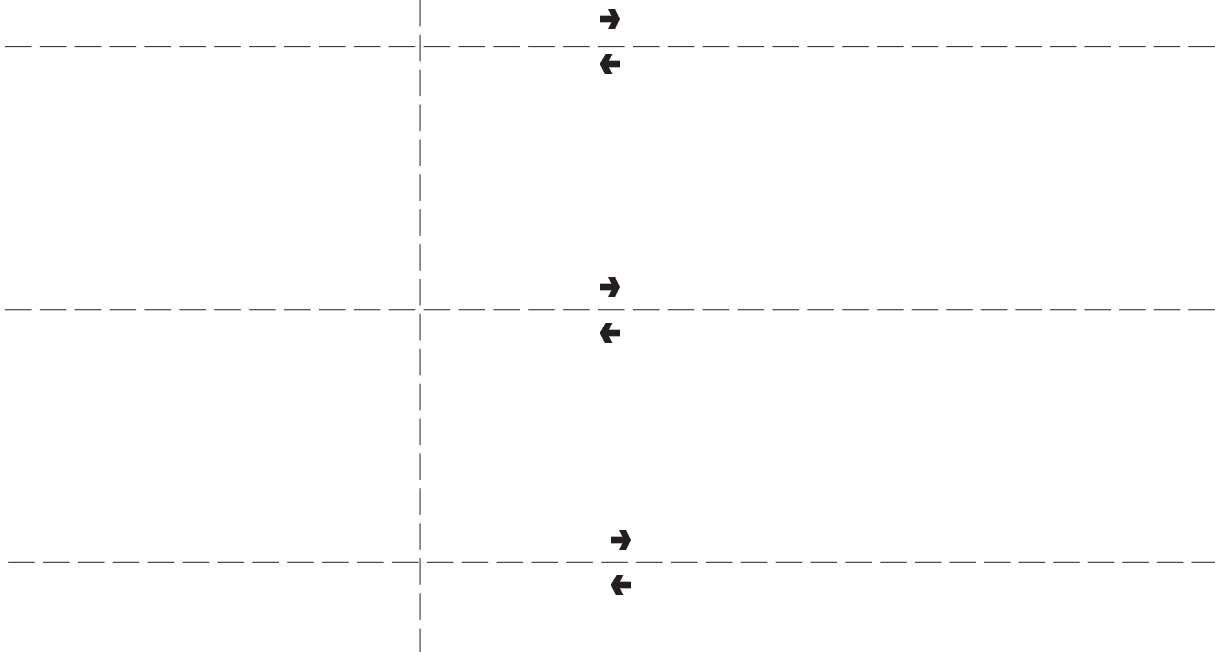

- ⊖ NEXT FUNCTION/
INCREASE DATA UNIT (+1)
- ⊕ PREVIOUS FUNCTION/
DECREASE DATA UNIT (-1)
- Ⓢ CONFIRM DATA/
CONFIRM FUNCTION
- Ⓣ DELETE DATA/
EXIT FUNCTION

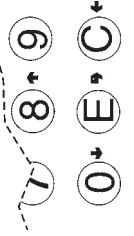

Technician menu - Summary

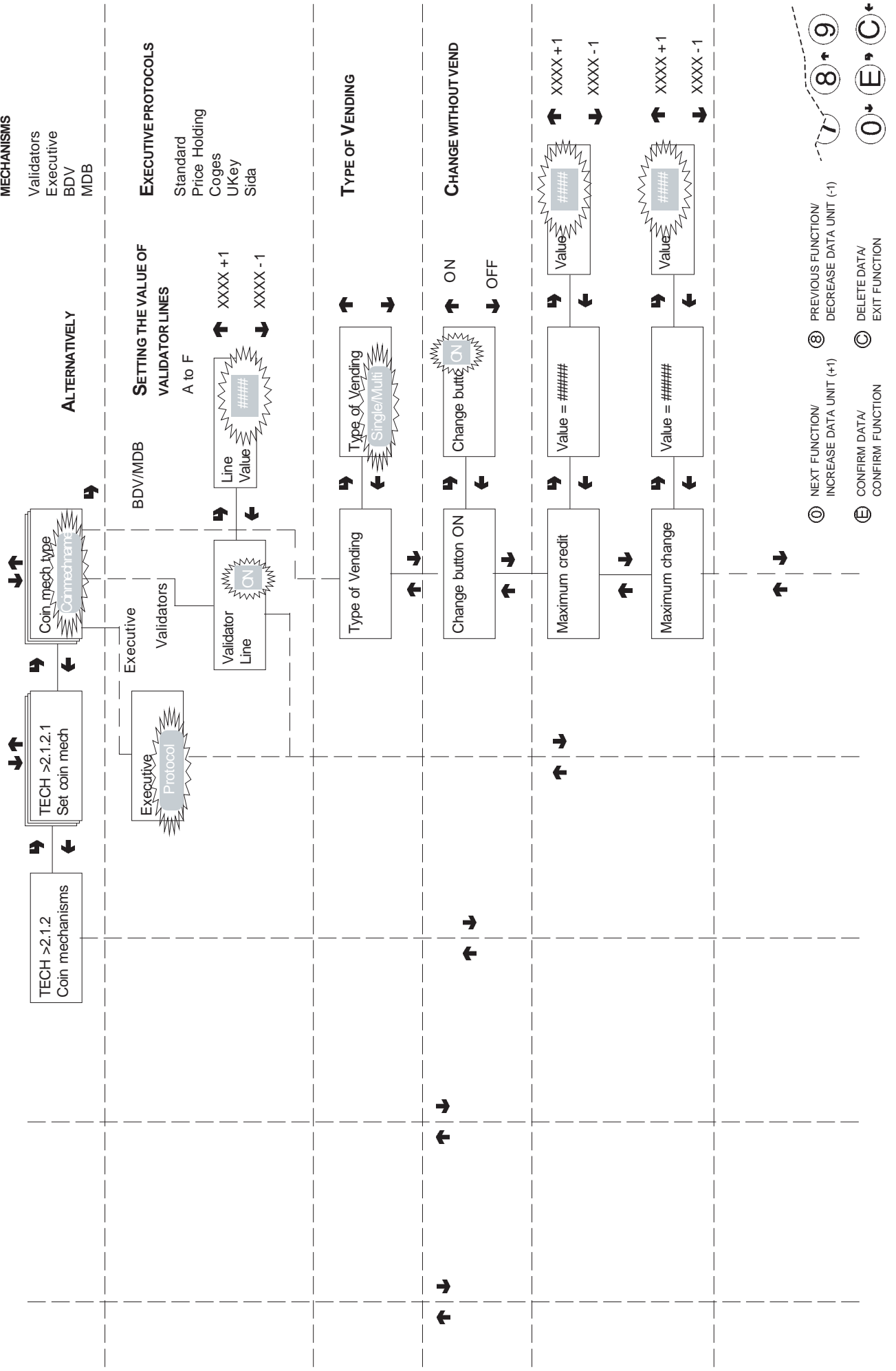

Technician menu - Summary

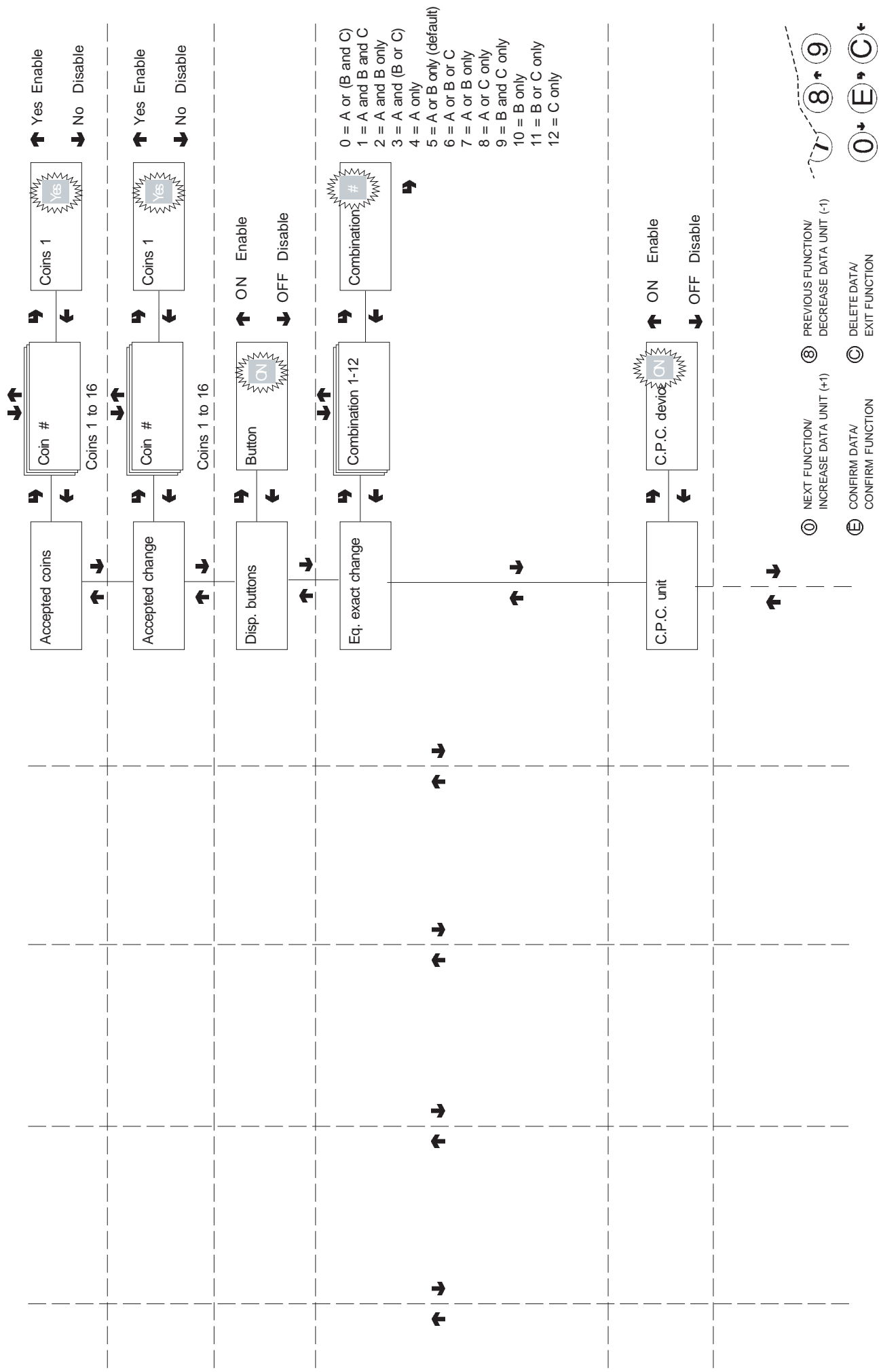

Technician menu - Summary

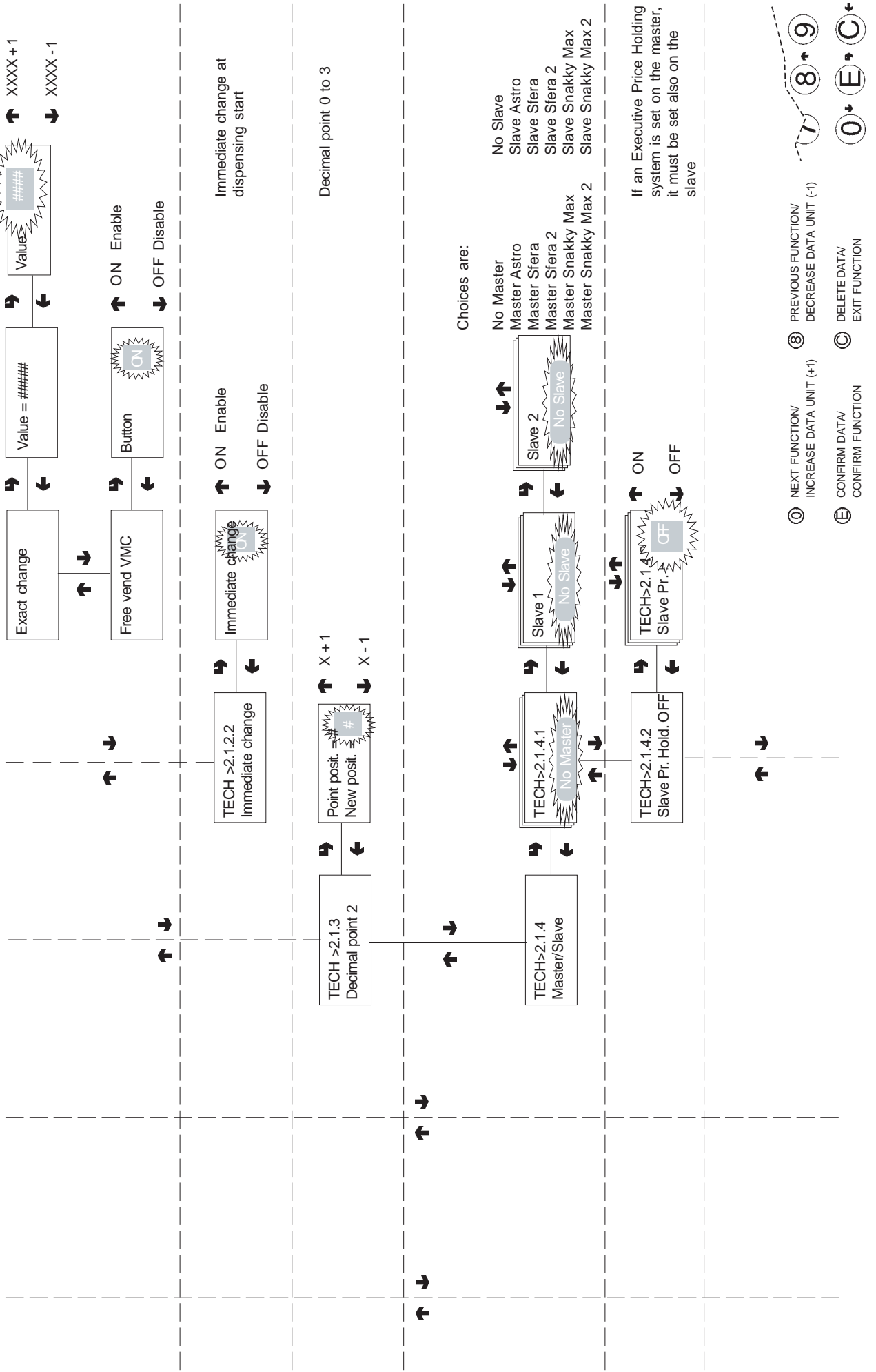

Technician menu - Summary

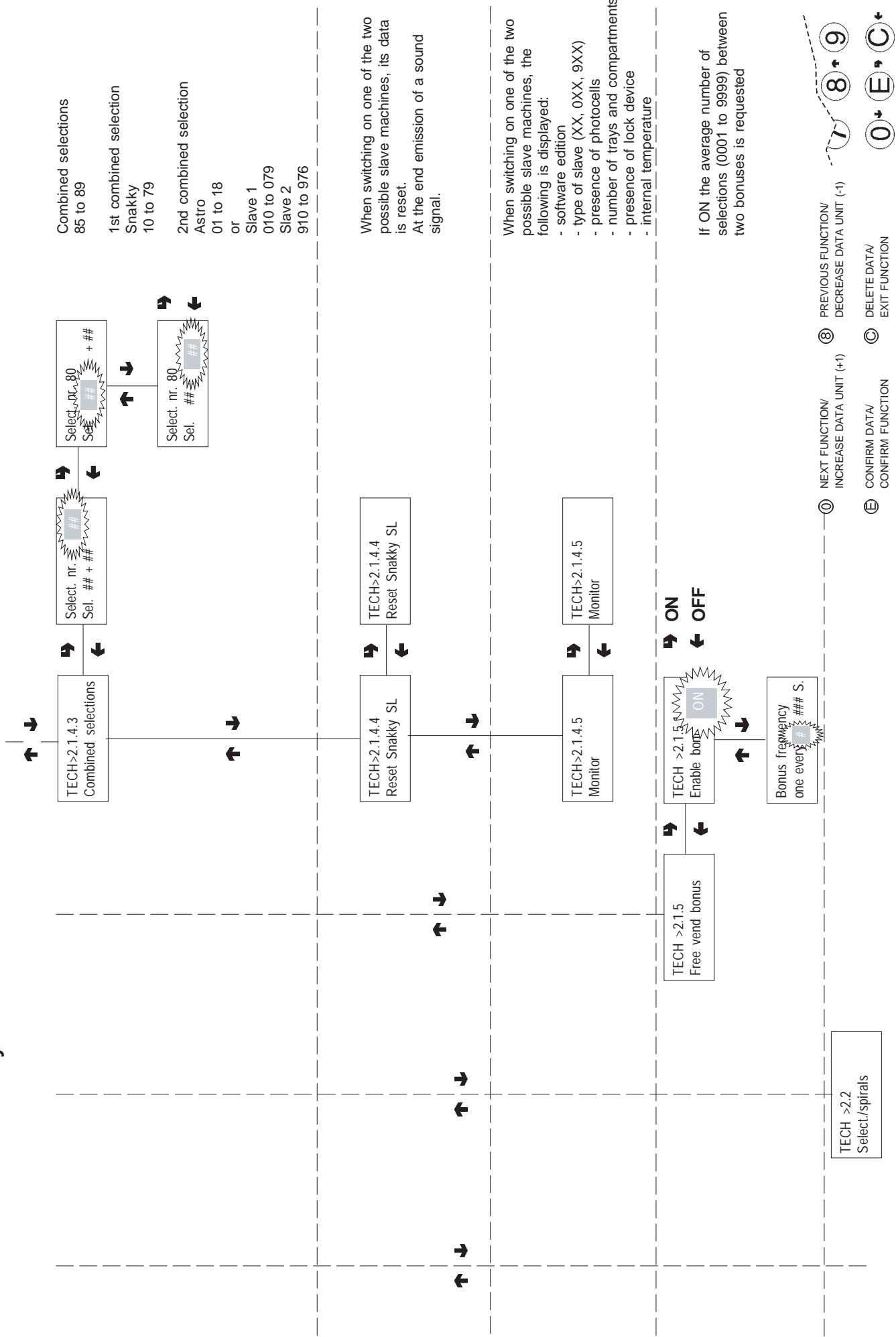

Technician menu - Summary

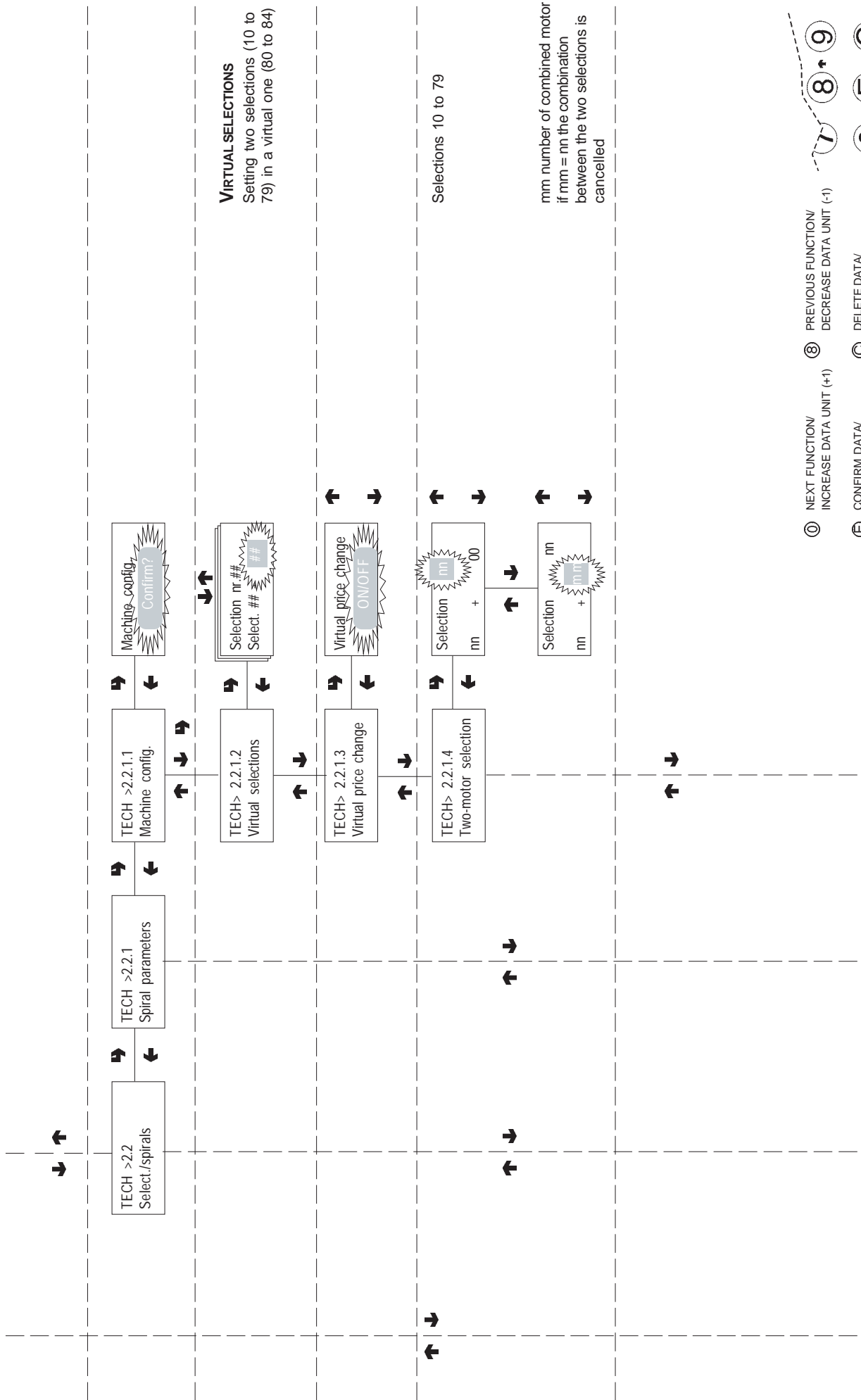

Technician menu - Summary

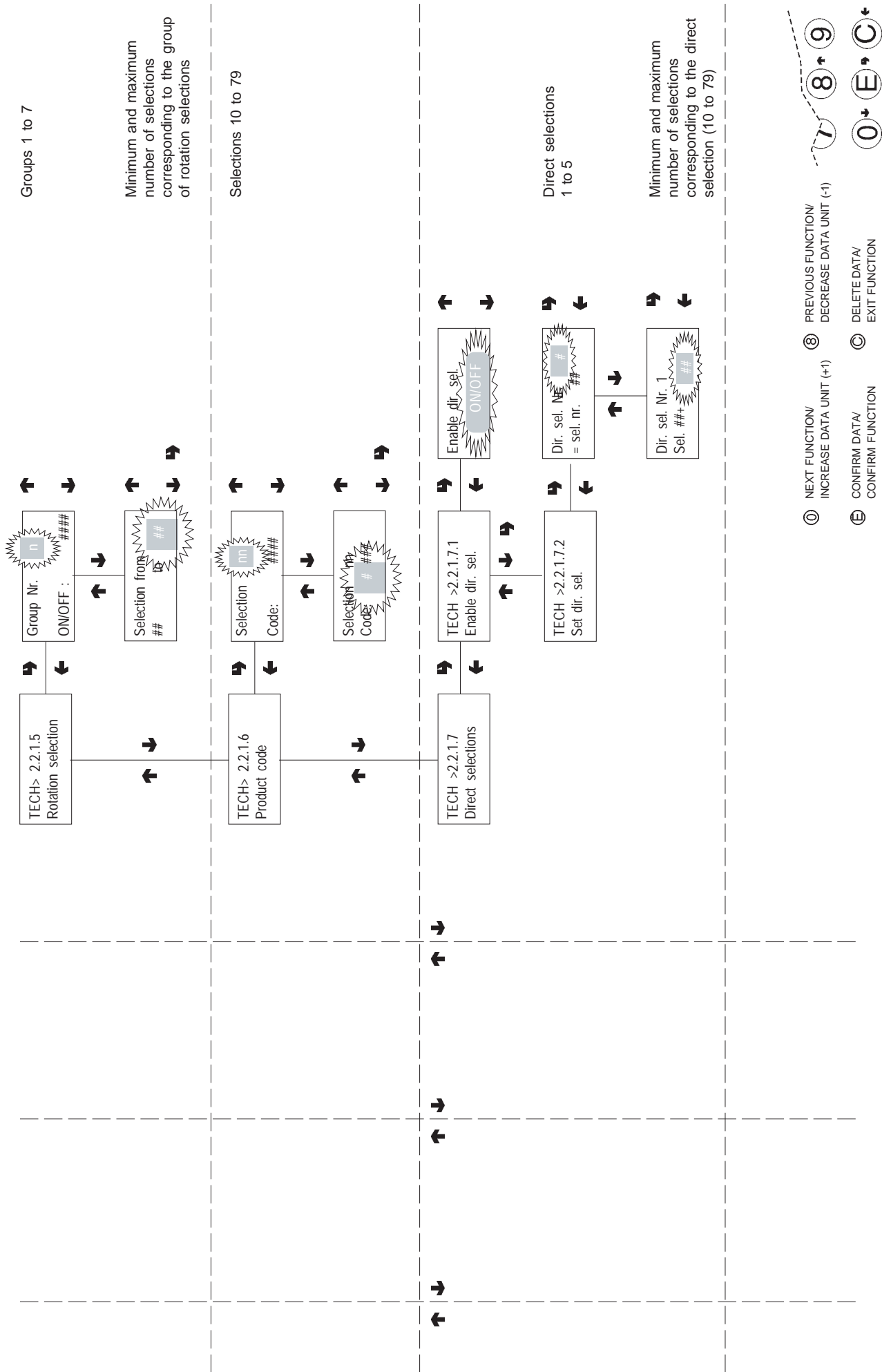

- ⊙ NEXT FUNCTION/ INCREASE DATA UNIT (+1)
- ⊙ PREVIOUS FUNCTION/ DECREASE DATA UNIT (-1)
- ⊙ CONFIRM DATA/ CONFIRM FUNCTION
- ⊙ DELETE DATA/ EXIT FUNCTION

Technician menu - Summary

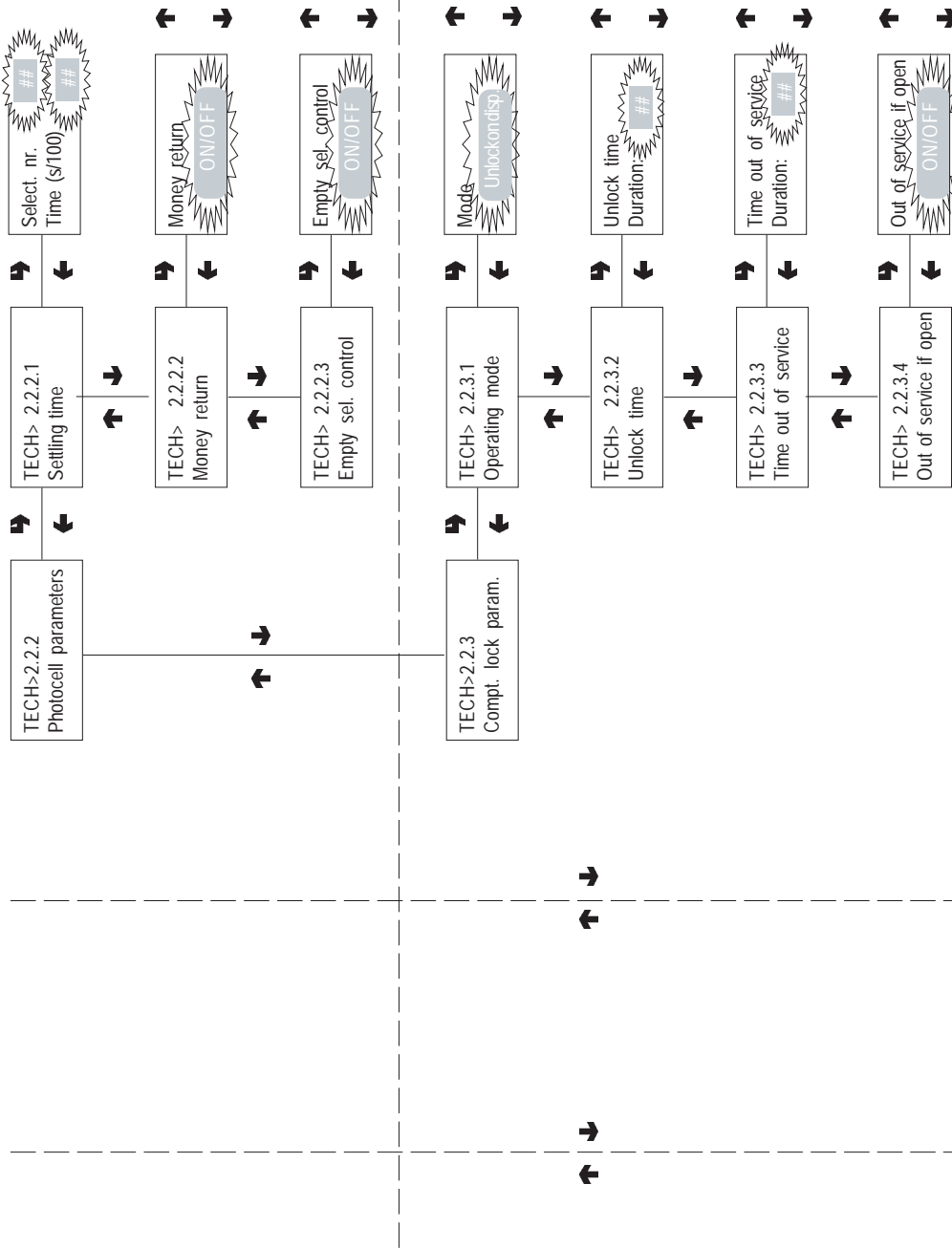

UNLOCK DISPENSING

COMPARTMENT

Always unlocked

Unlocked upon dispensing for ## minutes

01 to 10 minutes

01 to 10 minutes

Out of service if the compartment fails when open

Ⓢ NEXT FUNCTION/
INCREASE DATA UNIT (+1)

Ⓣ PREVIOUS FUNCTION/
DECREASE DATA UNIT (-1)

Ⓤ CONFIRM DATA/
CONFIRM FUNCTION

Ⓦ DELETE DATA/
EXIT FUNCTION

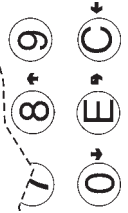

Technician menu - Summary

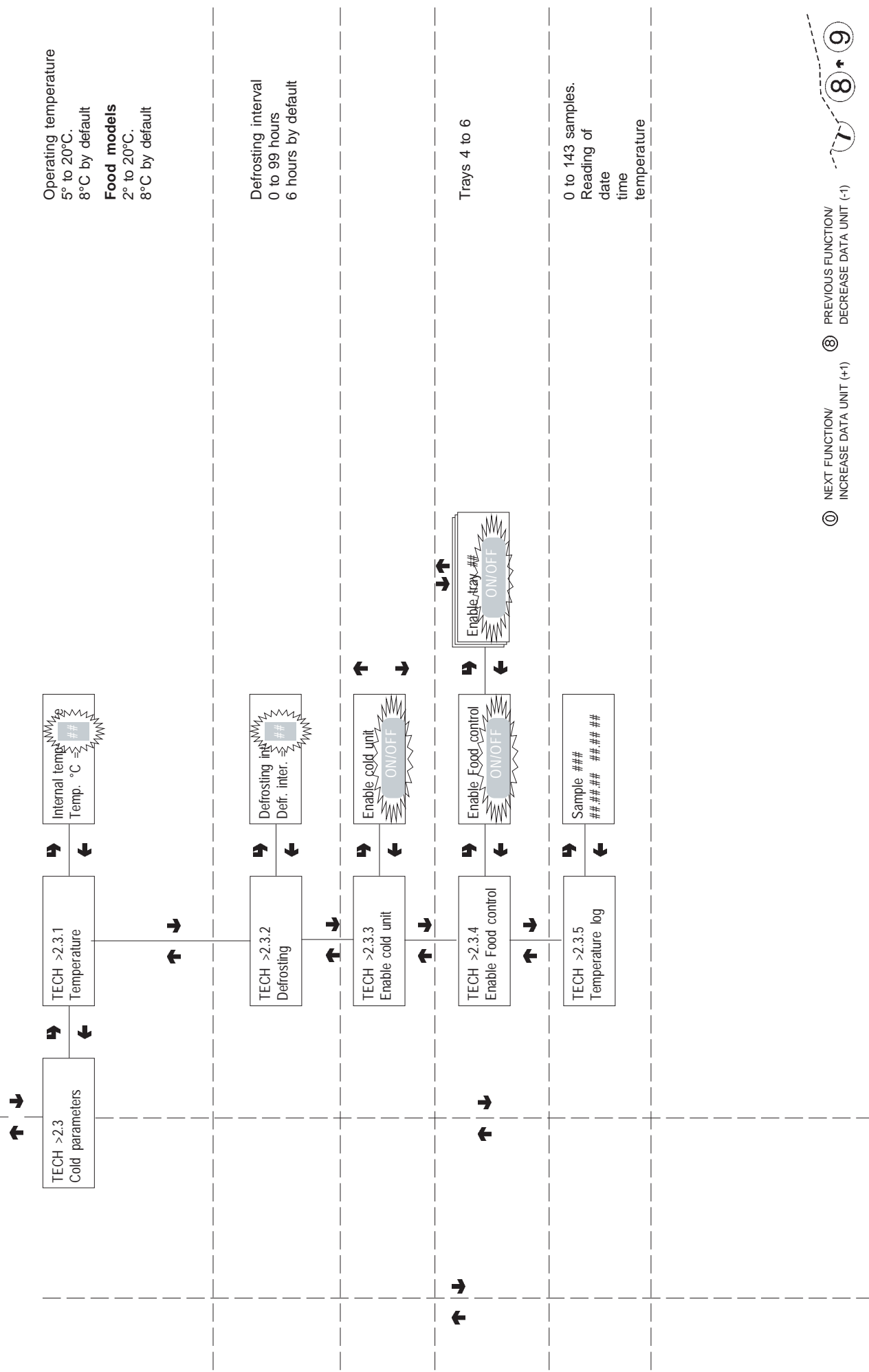

Technician menu - Summary

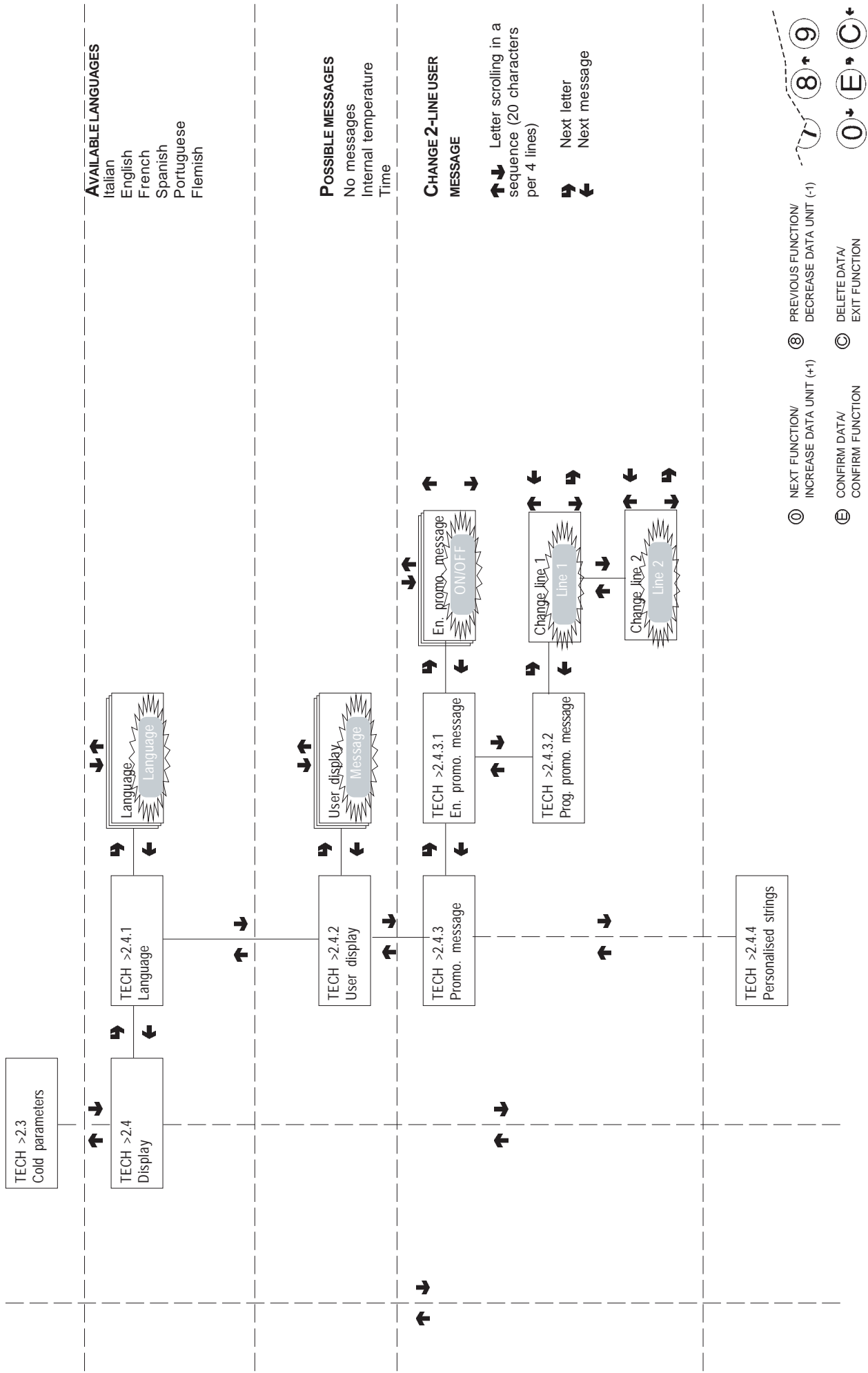

Technician menu - Summary

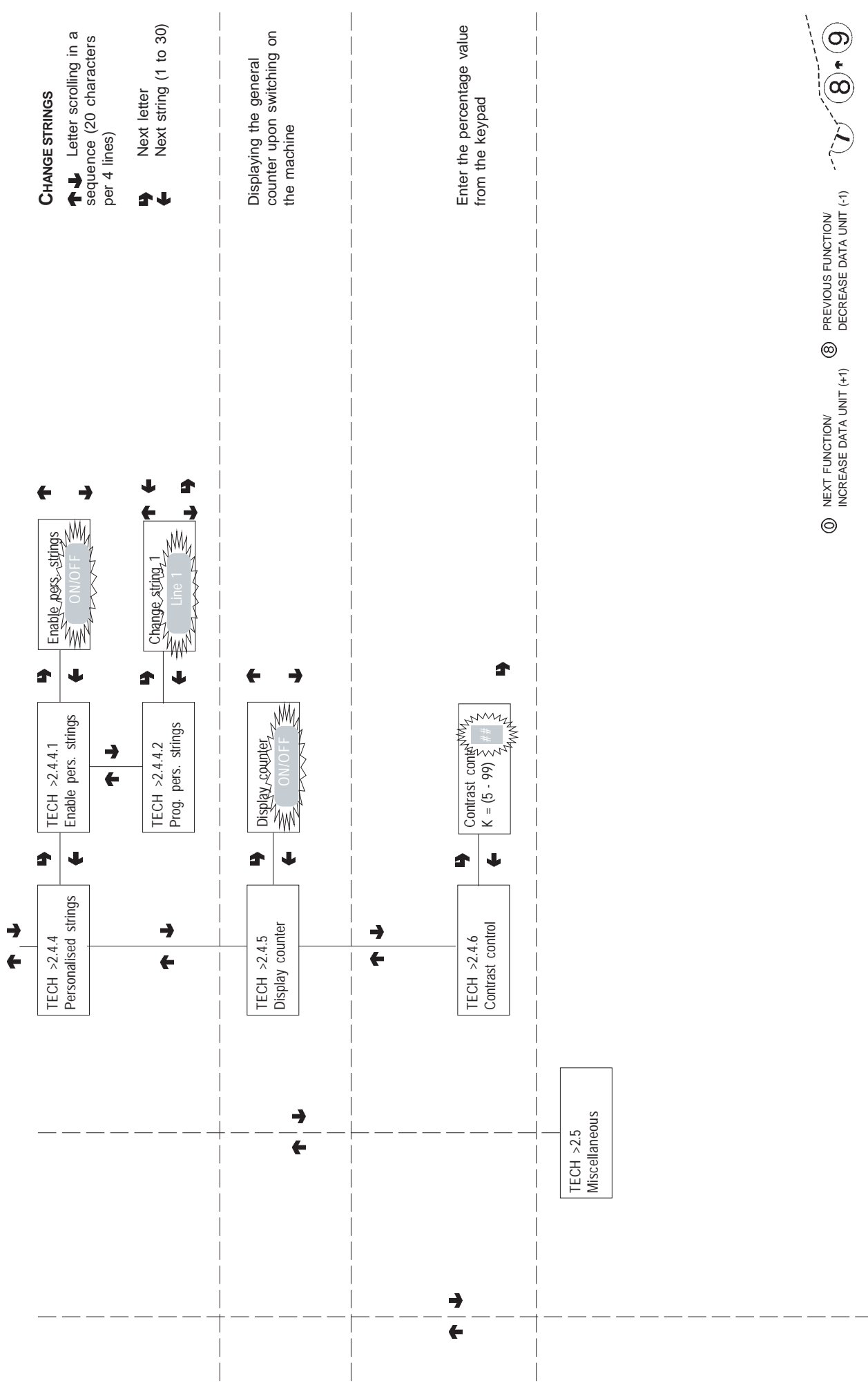

- Ⓢ NEXT FUNCTION/
INCREASE DATA UNIT (+1)
- Ⓣ PREVIOUS FUNCTION/
DECREASE DATA UNIT (-1)
- Ⓤ CONFIRM DATA/
CONFIRM FUNCTION
- Ⓟ DELETE DATA/
EXIT FUNCTION
- 7
- 8
- 9
- 0
- E
- C

Technician menu - Summary

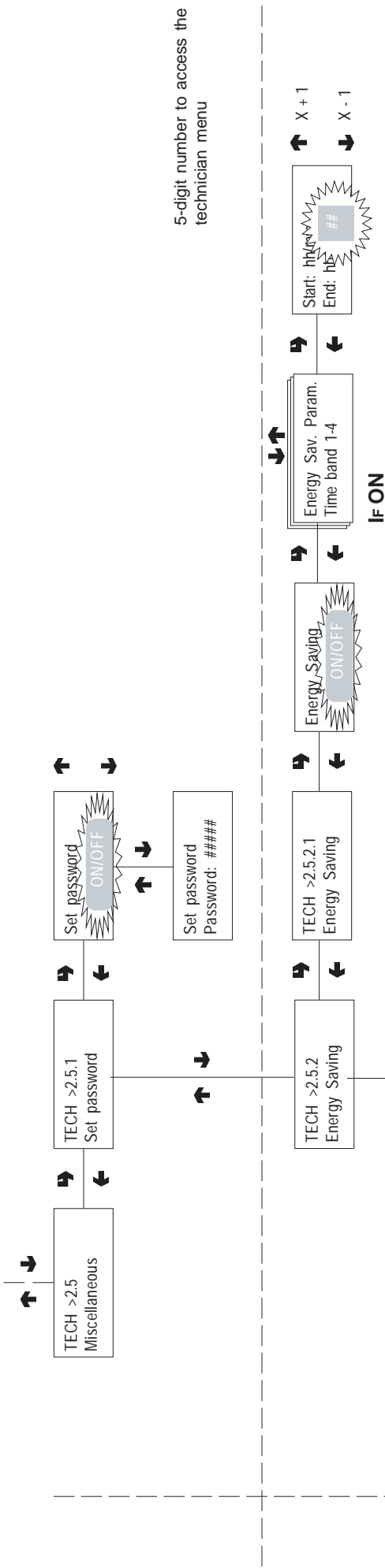

5-digit number to access the technician menu

When confirming the blinking values, hour and minute for start and end of time band are entered one after the other. When start and end of time band are set to 00.00 the bands are not activated.

FILLER MENU

- Statistics
- Single prices
- BDV tube control
- Special selections
- Test
- EVADTS connection

If ON, external lighting is switched off with vending machine out of service



- ① NEXT FUNCTION/ INCREASE DATA UNIT (+1)
- ② CONFIRM DATA/ CONFIRM FUNCTION
- ③ PREVIOUS FUNCTION/ DECREASE DATA UNIT (-1)
- ④ DELETE DATA/ EXIT FUNCTION

TECH >3 Statistics

Technician menu - Summary

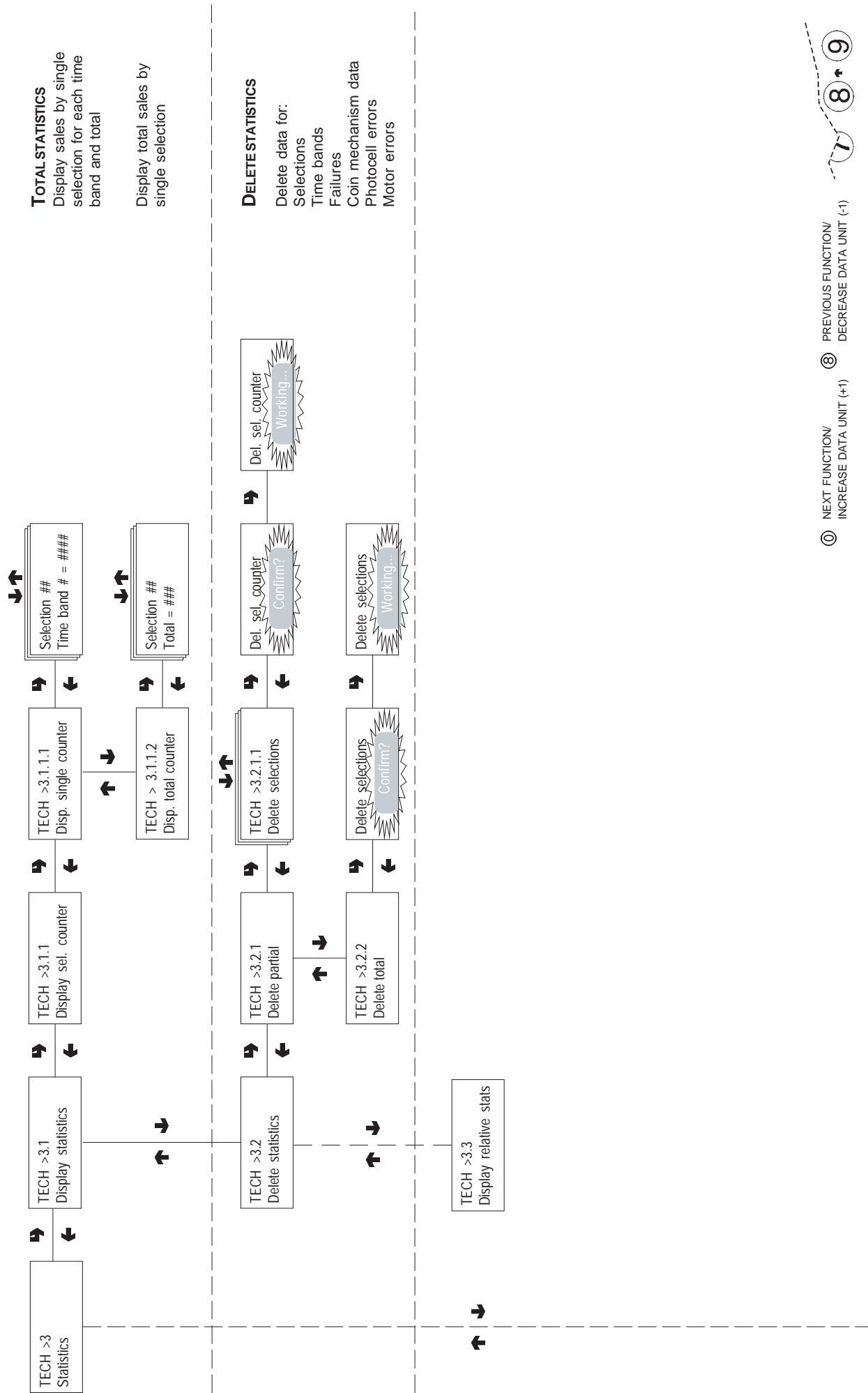

- Ⓢ NEXT FUNCTION/
INCREASE DATA UNIT (+1)
- Ⓣ PREVIOUS FUNCTION/
DECREASE DATA UNIT (-1)
- Ⓤ CONFIRM DATA/
CONFIRM FUNCTION
- Ⓥ DELETE DATA/
EXIT FUNCTION
- 7
- 8
- 9
- 0
- E
- C

Technician menu - Summary

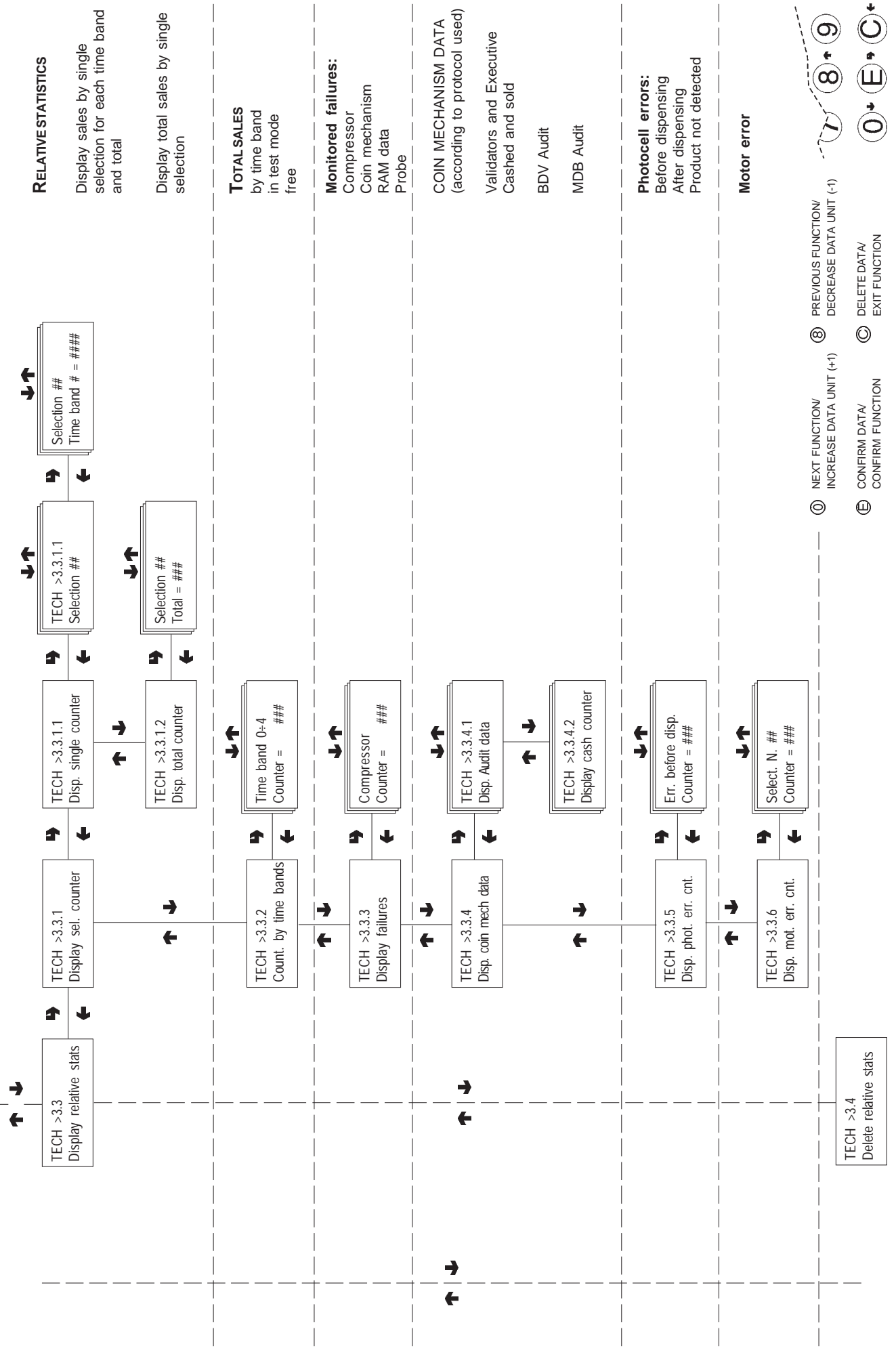

Technician menu - Summary

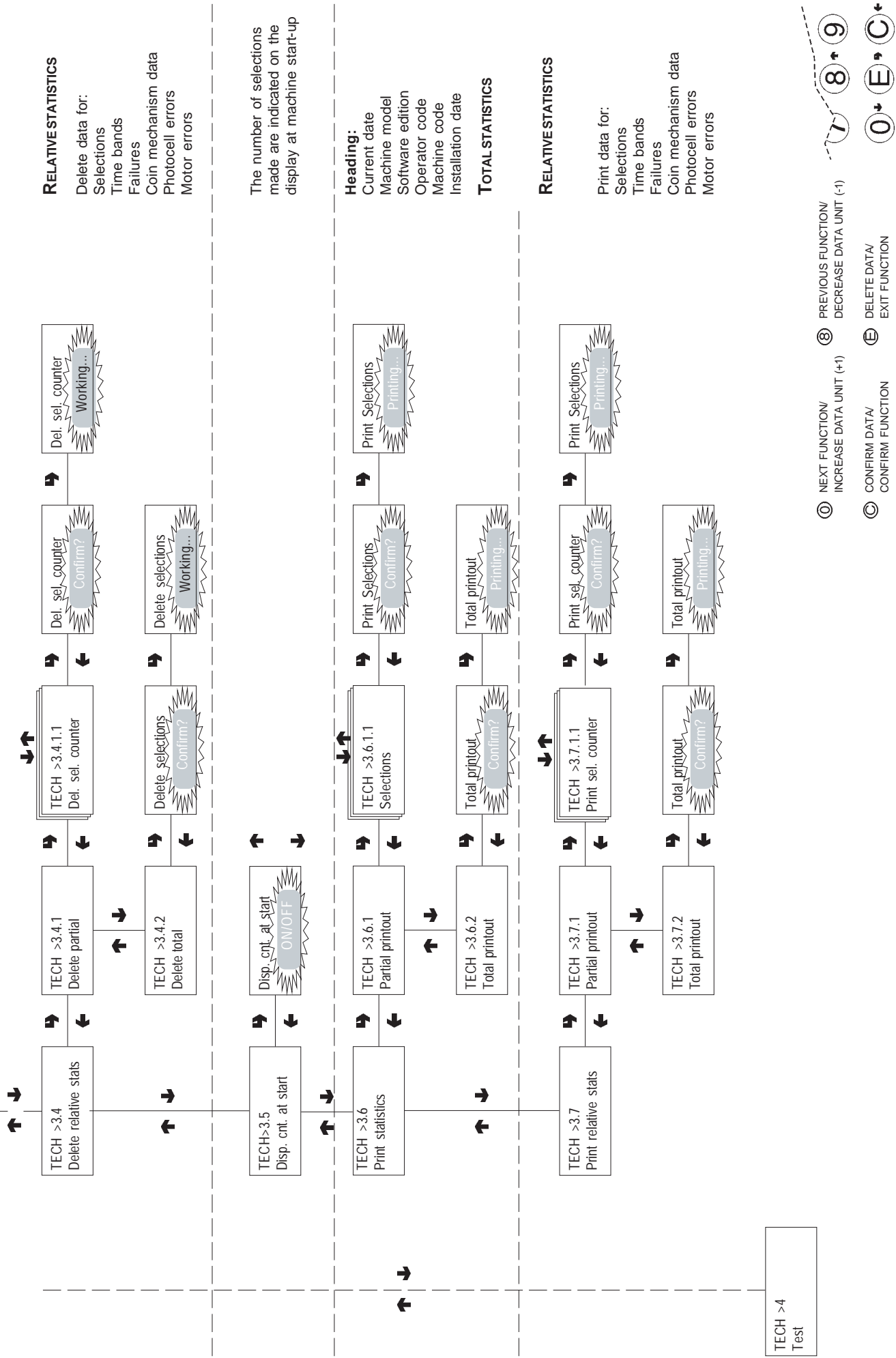

Technician menu - Summary

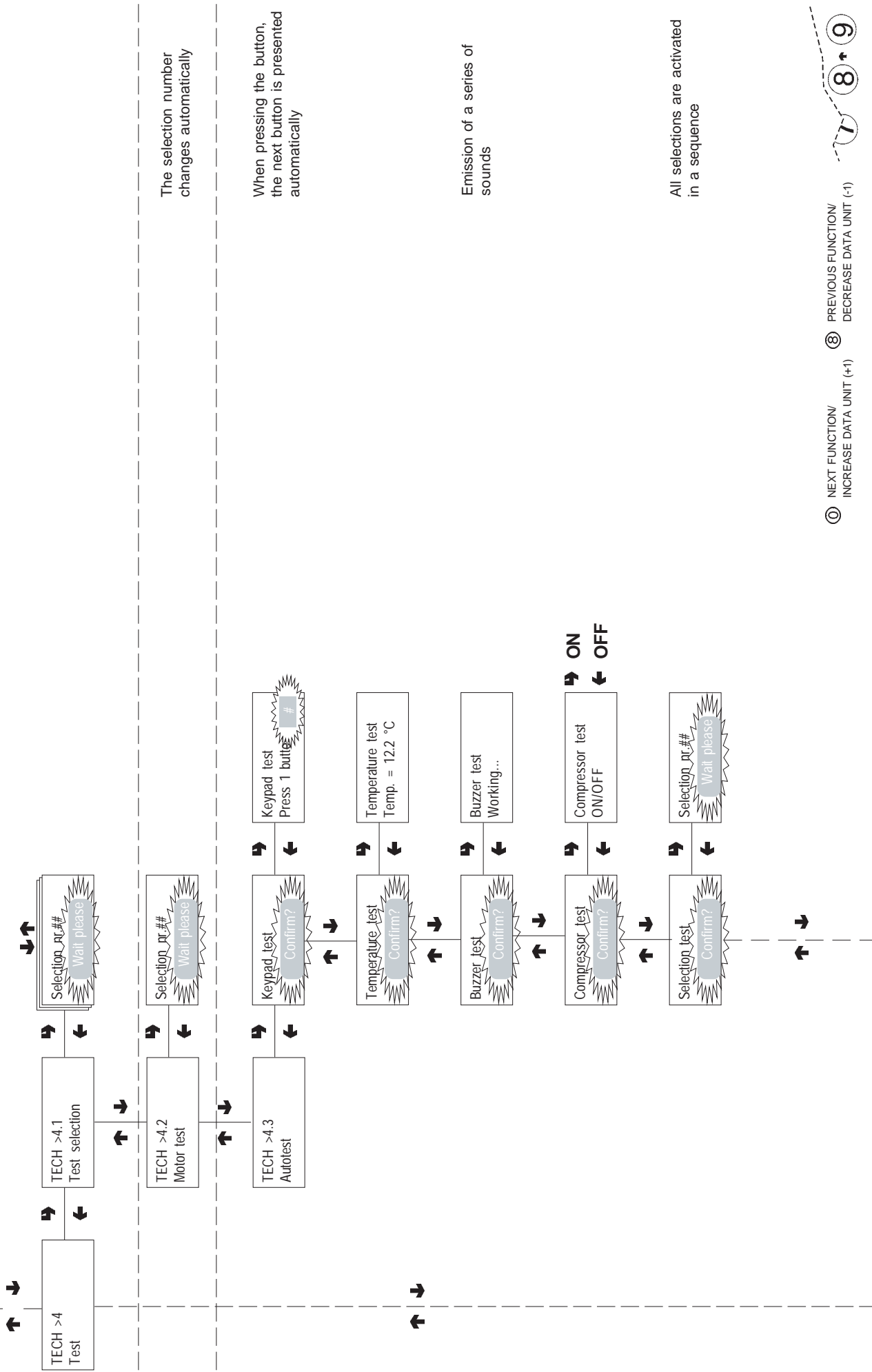

The selection number changes automatically

When pressing the button, the next button is presented automatically

Emission of a series of sounds

All selections are activated in a sequence

- ⓪ NEXT FUNCTION/ INCREASE DATA UNIT (+1)
- Ⓛ CONFIRM DATA/ CONFIRM FUNCTION
- Ⓜ PREVIOUS FUNCTION/ DECREASE DATA UNIT (-1)
- Ⓝ DELETE DATA/ EXIT FUNCTION

Technician menu - Summary

WITH EXECUTIVE OR BDV COIN MECHANISMS

If the coin mechanism communicates it displays "OK"

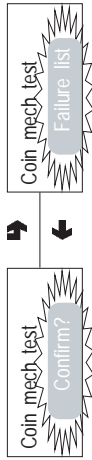

ALTERNATIVELY

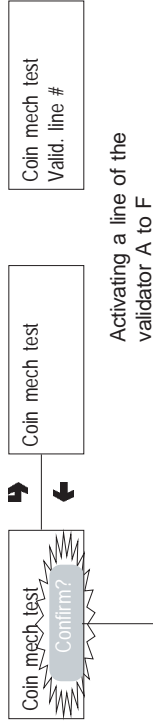

WITH A VALIDATOR

Line two remains for approximately 2 seconds

ALTERNATIVELY

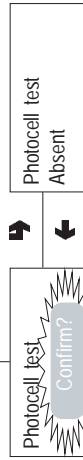

WITH PHOTOCELLS DISCONNECTED

WITH PHOTOCELLS

If the light beam is interrupted within 2.5 seconds it displays "OK" or Error no product If a failure is present:

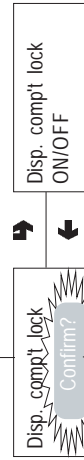
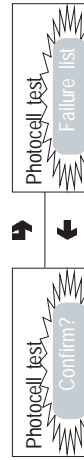

Error after dispensing Error before dispensing With dispensing compartment lock present

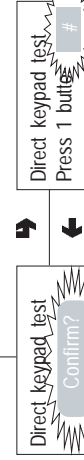

When pressing the button, the next button is presented automatically



Technician menu - Summary

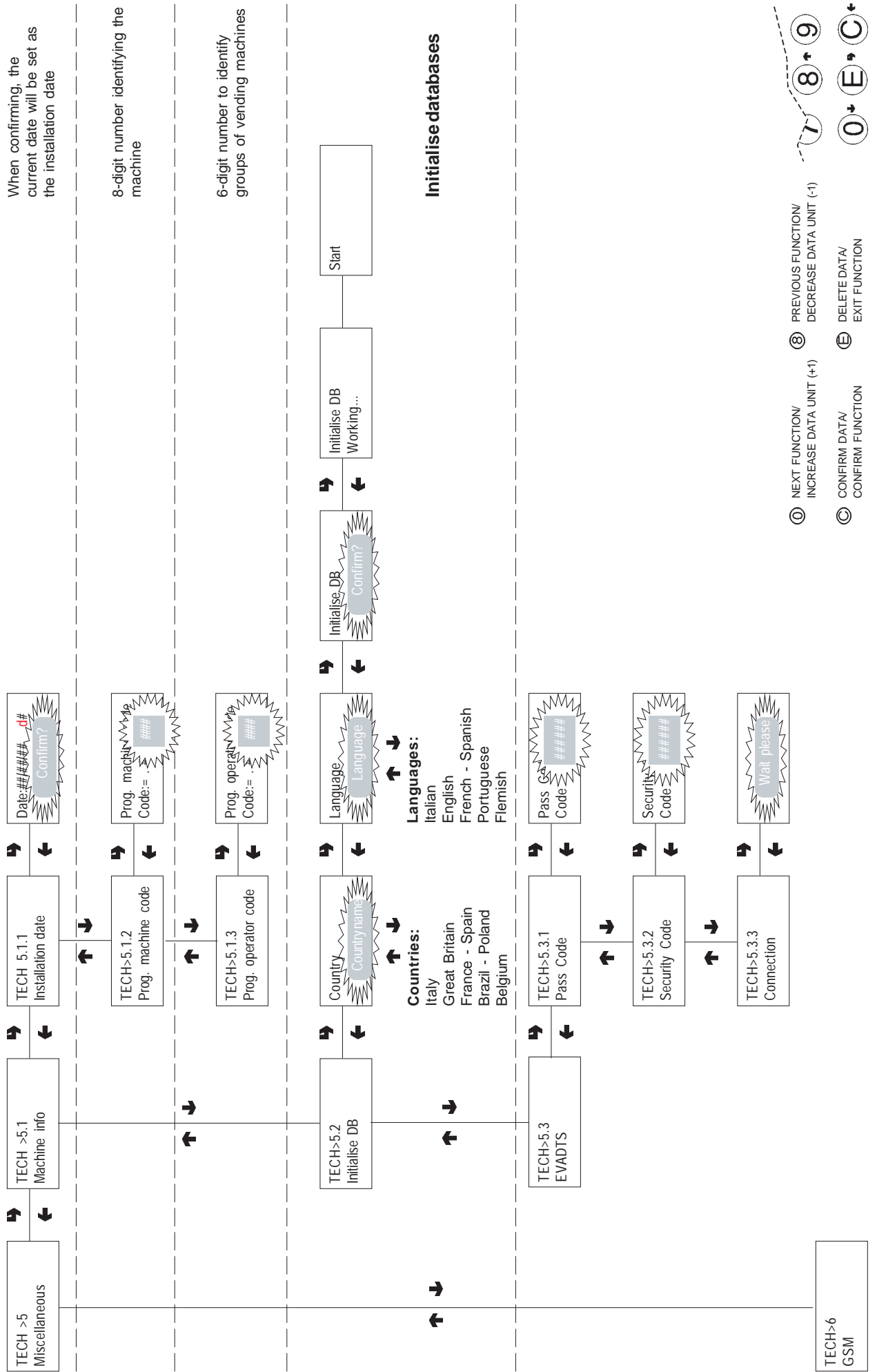

Technician menu - Summary

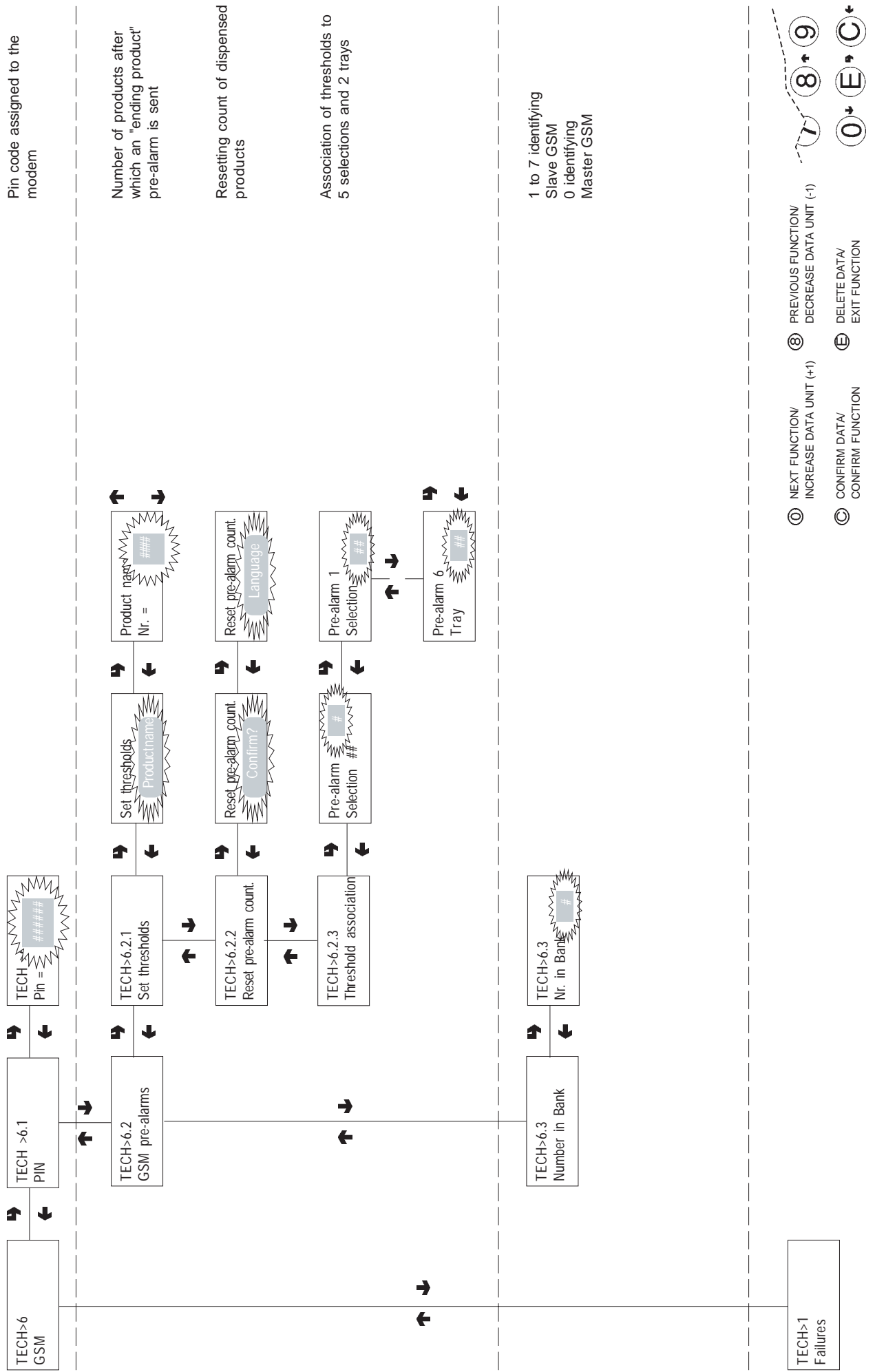

WIRING DIAGRAM LEGEND

INITIALS	DESCRIPTION	INITIALS	DESCRIPTION
CCB	CAN BUS CONNECTOR	MIP	PROGRAMMING ACCESS MICROSWITCH
CF	FILTER CONDENSER	MS1	HATCH MOTOR MICROSWITCH
CM0-9	VENDING MOTOR CAM	MUR	COMPRESSOR
CMV	DISPENSING COMPARTMENT MOTOR CAM	MVT	FAN
D	DIODE	NTC1-	TEMPERATURE PROBE
EX	CONNECTOR FOR EXECUTIVE COIN MECH	PIP	PROGRAMMING ACCESS BUTTON
FA	RADIO INTERFERENCE SUPPRESSOR	R	ANTI-CONDENSATION HEATING ELEMENT
FD	PHOTODIODE	RS232	SERIAL PORT
FT	PHOTOTRANSISTOR	RT	BALLAST
IP	DOOR SWITCH	SOR	OUT/R BOARD
ISA	OPEN HATCH SWITCH	SP	PUSH-BUTTON BOARD
LCD	LIQUID CRYSTAL DISPLAY	ST	STARTER
M1-...	RELEASE MOTOR	SUC	C.P.U. BOARD
MBV	DISPENSING COMPARTMENT LOCK MOTOR	TR	TRANSFORMER
MDB	CONNECTOR FOR MDB COIN MECH	TX...	DELAYED FUSE (X=COURRENT)

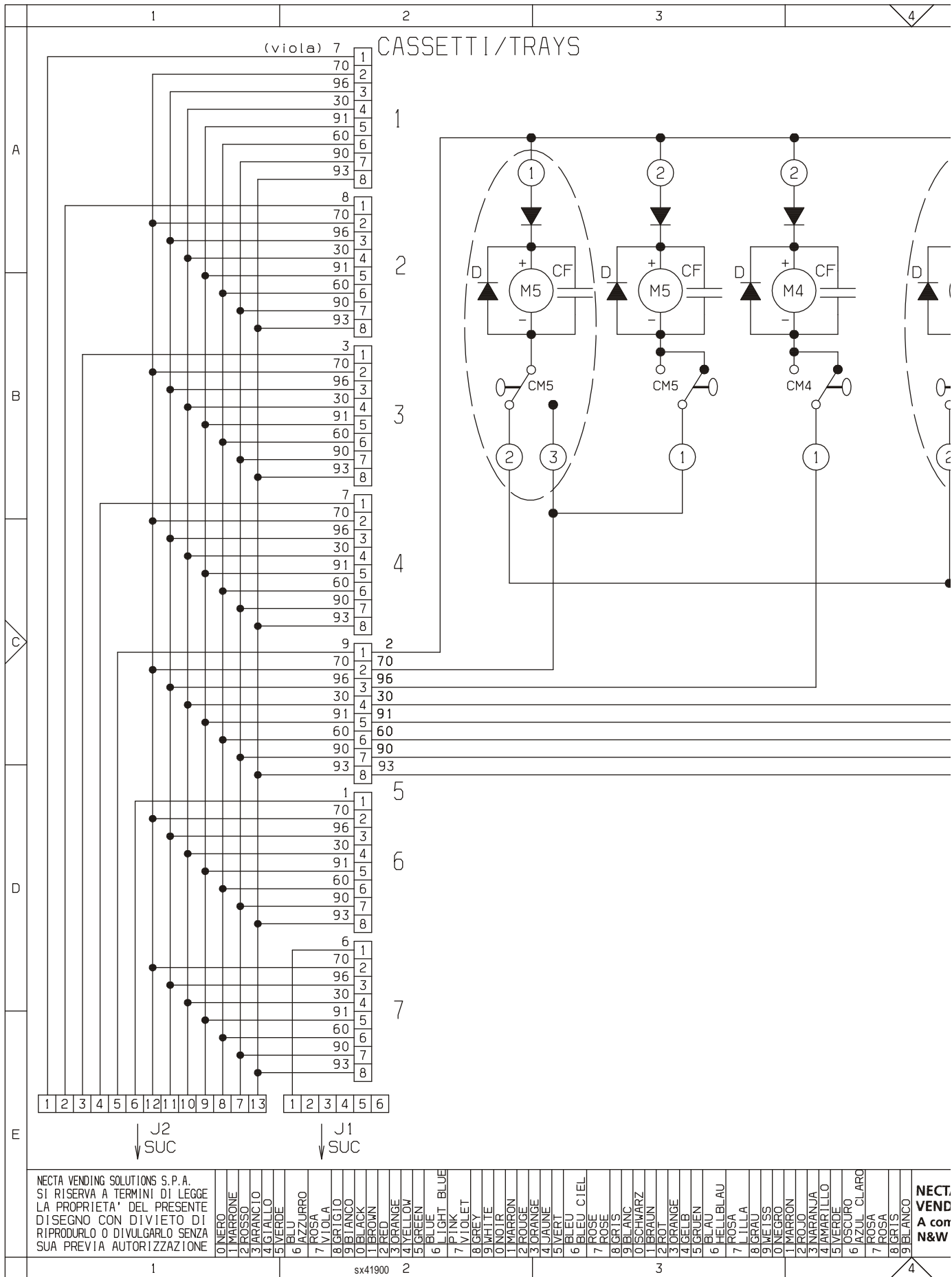

NECTA VENDING SOLUTIONS S.P.A.
 SI RISERVA A TERMINI DI LEGGE
 LA PROPRIETA' DEL PRESENTE
 DISEGNO CON DIVIETO DI
 RIPRODURLO O DIVULGARLO SENZA
 SUA PREVIA AUTORIZZAZIONE

0	NERO	1	MARRONE	2	ROSSO	3	ARANCIO	4	GIALLO	5	VERDE	6	BLU	7	AZZURRO	8	ROSA	9	VIOLA	10	GRIGIO	11	BIANCO	12	BLACK	13	BROWN	14	BROWN	15	ORANGE	16	ORANGE	17	YELLOW	18	GREEN	19	BLUE	20	LIGHT BLUE	21	PINK	22	VIOLET	23	GREY	24	WHITE	25	NOIR	26	MARRON	27	ROUGE	28	ORANGE	29	JAUNE	30	VERT	31	BLEU CIEL	32	ROSE	33	ROSE	34	GRIS	35	BLANC	36	SCHWARZ	37	ROU	38	ROU	39	ORANGE	40	GELB	41	GRUEN	42	BLAU	43	HELLBLAU	44	ROSA	45	LILLA	46	GRAU	47	WEISS	48	NEGRO	49	MARRON	50	ROJO	51	NARANJA	52	AMARILLO	53	VERDE	54	OSCURO	55	AZUL CLARO	56	ROSA	57	ROSA	58	GRIS	59	BLANCO	60	BLANCO
---	------	---	---------	---	-------	---	---------	---	--------	---	-------	---	-----	---	---------	---	------	---	-------	----	--------	----	--------	----	-------	----	-------	----	-------	----	--------	----	--------	----	--------	----	-------	----	------	----	------------	----	------	----	--------	----	------	----	-------	----	------	----	--------	----	-------	----	--------	----	-------	----	------	----	-----------	----	------	----	------	----	------	----	-------	----	---------	----	-----	----	-----	----	--------	----	------	----	-------	----	------	----	----------	----	------	----	-------	----	------	----	-------	----	-------	----	--------	----	------	----	---------	----	----------	----	-------	----	--------	----	------------	----	------	----	------	----	------	----	--------	----	--------

NECTA
 VEND
 A con
 N&W





4	5	6	7
---	---	---	---

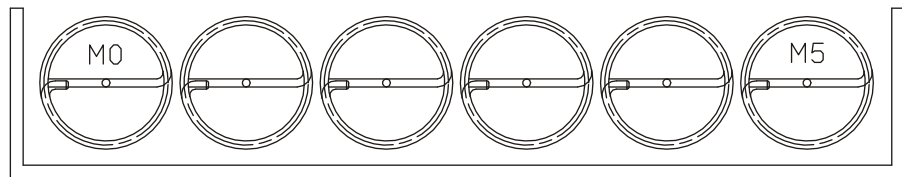
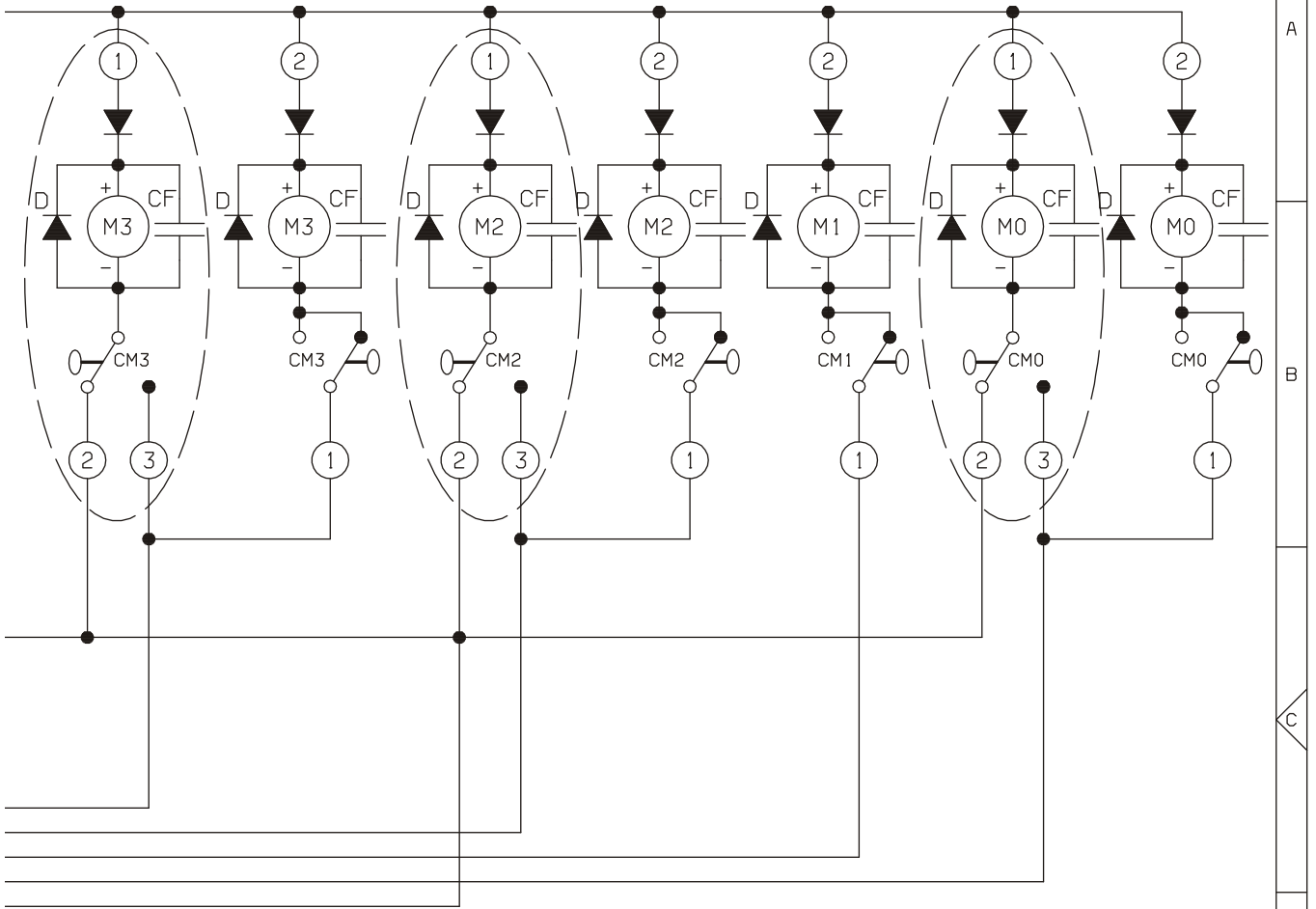

IBERLIS 99 BILANCO	NECTA VENDING SOLUTIONS SpA A company of N&W GLOBAL VENDING GROUP	MODELLO Snakky <i>Max</i>	GRUPPO SCHEMA ELETTRICO FUNZIONALE CASSETTI	DATA 05-11-03	FOGLIO 1/1	DISEGNATO BONACINA	CONTROLLATO MONGUZZI
			LEGENDA		CODICE 608541900		
	4	5	6	7			



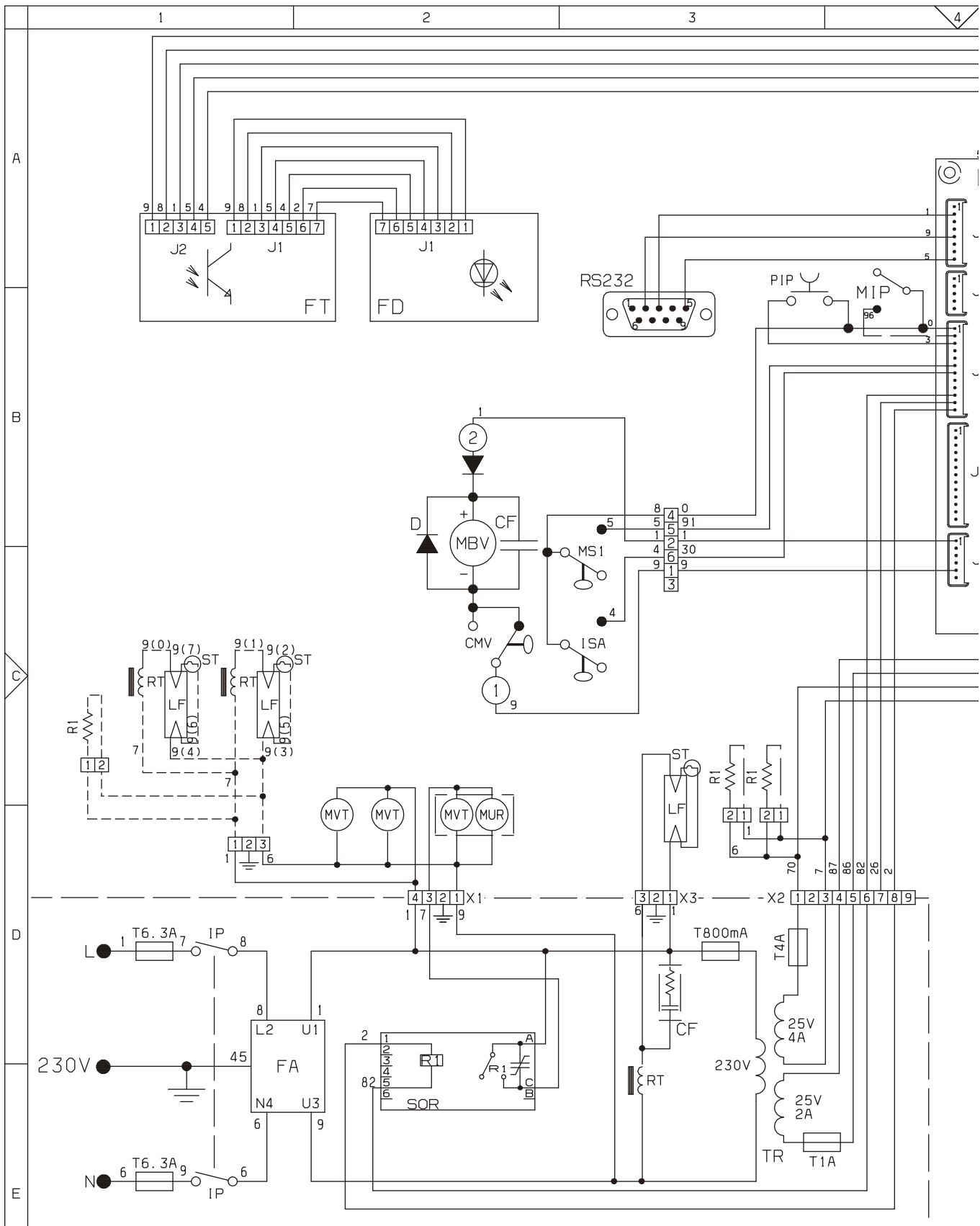

NECTA VENDING SOLUTIONS S.P.A.
 SI RISERVA A TERMINI DI LEGGE
 LA PROPRIETA' DEL PRESENTE
 DISEGNO CON DIVIETO DI
 RIPRODURLO O DIVULGARLO SENZA
 SUA PREVIA AUTORIZZAZIONE

0	NERO	1	MARRONE	2	ROSSO	3	ARANCIO	4	GIALLO	5	VERDE	6	BLU	7	AZZURRO	8	ROSA	9	VIOLA	0	GRIGIO	1	BIANCO	2	BLACK	3	BROWN	4	RED	5	ORANGE	6	YELLOW	7	GREEN	8	BLUE	9	LIGHT BLUE	0	PINK	1	VIOLET	2	GREY	3	WHITE	4	NOIR	5	MARRON	6	ROUGE	7	ORANGE	8	JAUNE	9	VERT	0	BLEU CIEL	1	ROSE	2	ROSE	3	GRIS	4	SCHWARZ	5	SCHWARZ	6	ROT	7	ORANGE	8	GELB	9	GRUEN	0	BLAU	1	BLAU	2	BLAU	3	ROSA	4	ROSA	5	GRAU	6	WEISS	7	WEISS	8	NEGRO	9	MARRON	0	ROJO	1	ROJO	2	NARANJA	3	NARANJA	4	AMARILLO	5	VERDE	6	VERDE	7	OSCURO	8	AZUL CLARO	9	AZUL CLARO	0	ROSA	1	ROSA	2	GRIS	3	GRIS	4	BLANCO
---	------	---	---------	---	-------	---	---------	---	--------	---	-------	---	-----	---	---------	---	------	---	-------	---	--------	---	--------	---	-------	---	-------	---	-----	---	--------	---	--------	---	-------	---	------	---	------------	---	------	---	--------	---	------	---	-------	---	------	---	--------	---	-------	---	--------	---	-------	---	------	---	-----------	---	------	---	------	---	------	---	---------	---	---------	---	-----	---	--------	---	------	---	-------	---	------	---	------	---	------	---	------	---	------	---	------	---	-------	---	-------	---	-------	---	--------	---	------	---	------	---	---------	---	---------	---	----------	---	-------	---	-------	---	--------	---	------------	---	------------	---	------	---	------	---	------	---	------	---	--------



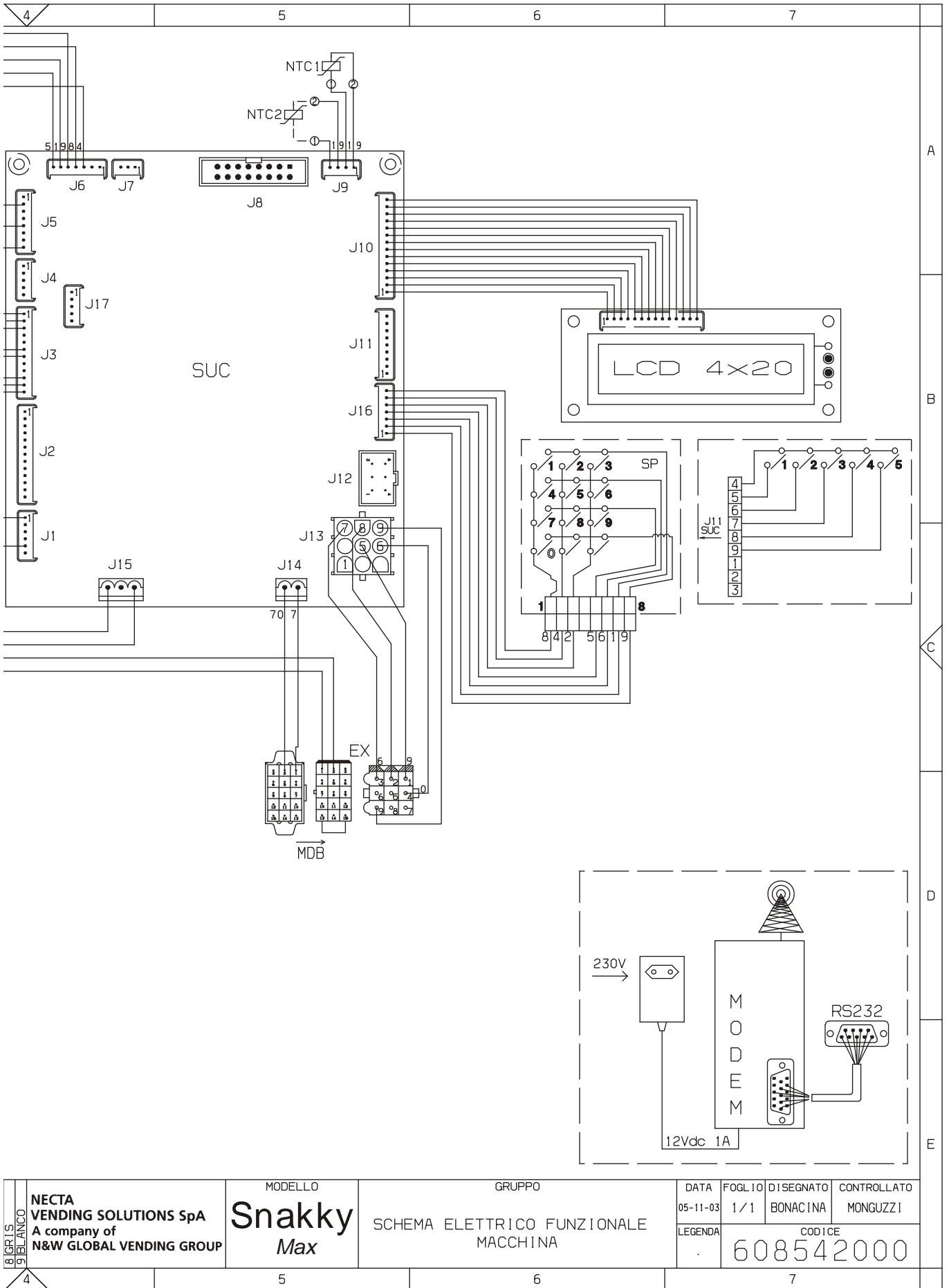

8 GRIS 9 BLANCO	NECTA VENDING SOLUTIONS SpA A company of N&W GLOBAL VENDING GROUP	MODELLO Snakky Max	GRUPPO SCHEMA ELETTRICO FUNZIONALE MACCHINA	DATA 05-11-03	FOGLIO 1/1	DISSEGNA TO BONACINA	CONTROLLATO MONGUZZI
	LEGENDA						CODICE 608542000
	4	5	6	7			



The Manufacturer reserves the right to modify, without prior notice, the characteristics of the equipment described in this publication; and further declines to accept any responsibility for any inaccuracies contained in this publication which can be ascribed to printing and/or transcription errors.

All instructions, drawings, tables and information contained in this publication are confidential and can neither be reproduced completely or in part, nor be transmitted to third parties without the written permit of the Manufacturer, who has the sole ownership.

EDITION 2004 07 CODE: H 239U 00

